



2016

## Complete Volume 2

Follow this and additional works at: <https://digitalcommons.winthrop.edu/wmrb>

---

### Recommended Citation

(2016) "Complete Volume 2," *The Winthrop McNair Research Bulletin*: Vol. 2, Article 15.  
Available at: <https://digitalcommons.winthrop.edu/wmrb/vol2/iss1/15>

This Article is brought to you for free and open access by the Winthrop University McNair Scholars Program at Digital Commons @ Winthrop University. It has been accepted for inclusion in The Winthrop McNair Research Bulletin by an authorized editor of Digital Commons @ Winthrop University. For more information, please contact [digitalcommons@mailbox.winthrop.edu](mailto:digitalcommons@mailbox.winthrop.edu).

<b>Table of Contents</b>	<b>Page</b>
<b>Incorporating Multicultural Education into Teacher Preparation Programs</b> by Ashley Renee Causey and Jeannie Haubert, Ph.D. (Mentor)	2
<b>How Do Family Background and Self-Esteem Affect an Individual's Perception of Gender-Role Portrayal in Online Advertisements?</b> by Cera Crowe and Aimee Meader, Ph.D. (Mentor)	8
<b>LGBTQ Emerging Adults: Their Experiences with Homelessness</b> by Jesse Lee Grainger and Brent Cagle, Ph.D. (Mentor)	16
<b>Using a BCI to Assess Attention During an Online Lecture</b> by Ethan Hanner and Marguerite Doman, Ph.D. (Mentor)	27
<b>Comparing the tensile and compressive Young's moduli of cortical bone</b> by Deshawn Hoskins and Meir Barak, Ph.D., D.V.M. (Mentor)	33
<b>Determination of phylo-group diversity of <i>Escherichia coli</i> in environmental sand samples collected from a South Carolina beach</b> by Savannah Moritzky; Victoria Frost, Ph.D.; and Matthew Heard, Ph.D. (Mentors)	40
<b>Expression, Purification, and Crystallization of an Endoxylanase from <i>Bacteroides Vulgatus</i></b> by Jesslyn Park and Jason Hurlbert, Ph.D. (Mentor)	45
<b>Creating Narratives through Art as Self-Definition for Black Women</b> by Shannon Snelgrove and Laura Gardner, Ph.D. (Mentor)	51
<b>Creating a microcosm to examine salinity tolerance of <i>Escherichia coli</i> in beach sand</b> by Leigha Stahl; Victoria Frost, Ph.D.; and Matthew Heard, Ph.D. (Mentors)	56
<b>The Case of Affirmative Action in Undergraduate Admissions: United States and Brazil</b> by Taylor Toves and Adolphus Belk, Jr., Ph.D. (Mentor)	62
<b>Instilling Resilience in Children of Poverty</b> by Alexis Williamson and Bradley Witzel, Ph.D. (Mentor)	70

# Incorporating Multicultural Education into Teacher Preparation Programs

Ashley Renee Causey  
Jeannie Haubert, Ph.D. (Mentor)

## ABSTRACT

In this comparative study, the discussion of multicultural education focused on these four research questions: “What is multicultural education?” “How are teaching preparation programs approaching multicultural education?” “What does multicultural education look like in the classroom?” and “Is multicultural education an explicit portion of teacher preparation programs for pre-service teachers in South Carolina?” Using James A. Banks’s five dimensions of multicultural education as the theoretical framework for the study, the following dimensions were explored to see if they were present within teacher preparation programs: content integration, knowledge construction, equity pedagogy, prejudice reduction, and empowering school culture and social structure. Interviews were conducted with faculty members, who met the following criteria: (1) a research interest in multicultural education, (2) experience with teaching a course for multicultural education or a related course about diversity, and (3) are teaching at a university or college with a Teaching Fellow Program in South Carolina. Along with interviews, an analysis of literature addressing the research questions was conducted. The results from the research were the following: Content integration, knowledge construction, and prejudice reduction were present within teacher preparation programs through required literature, writing assignments, and conversations that were structured into the syllabus to challenge the ideas and opinions that they brought into the classroom. Equity pedagogy and empowering a school culture and social structure were not present within teacher preparation programs. The implication for this research is that we must go beyond the common rhetoric of “inclusivity and multicultural understanding” because the classroom is not a utopia. It does not exist in its own world; it is a smaller environment that children grow, learn, and develop in preparation for a much larger environment—the world. Students need to learn how to engage in a healthy dialogue about those issues and learn how to dismantle the –isms that have been embedded within social policy, the judicial system, employment, and other pathways to access. A way to achieve this is that universities and colleges do not need to increase courses, but enrich those courses. By taking a closer look at the essential readings of offered courses, writing assignments, discussions, and service learning opportunities, a deeper analysis can be added to see if different races, ethnicities, religions, genders, nations, and sexual orientations are represented within the curriculum.

## LITERATURE REVIEW

The National Center for Education Statistics (NCES) states that by the year 2023, 55 percent of students receiving public primary and secondary education will be students of color (2013). In the midst of a changing student demographic, the average teacher is predominately white, female, and middle class (Gorski, 2012). In fact, 81.9 percent of teachers in public and private primary and secondary education identify as white (National Center for Educational Statistics, 2013). All teachers

regardless of race, class, religion, gender, sexual orientation or language bring their own biases (Gorski, 2012) into their teacher preparation programs, and it is up to these programs to encourage reflexivity to protect against potential biases. With the changing demographics of students, a deeper and more critical discussion of how teachers are being taught to address diversity in the classroom needs to occur.

The term diversity can refer to a variety of social statuses, but for the context of this paper, I will limit my discussion of diversity to

race, and ethnicity. These are the criteria that Banks (1994) uses as a focus to multicultural education. Arguably, the purpose of education involves, “developing the intellect, serving social needs, contributing to the economy, creating an effective work force, preparing students for a job or career, promoting a particular social or political system” (Forshay, 2012). Students cannot truly serve the “social needs” or to “promote a particular social or political system” if they are not being taught how to critically think and examine the current structures of society, including racial structures. A student learns about individuals belonging to other groups via television and internet, family, and sometimes through peer interactions, but this information is often incomplete or distorted. Therefore educators must also explicitly teach children how to learn to “think critically, how to recognize discrimination and injustice, and to work to challenge injustice” (Handbook of Research on the Education of Young Children, 2012). It is important for teachers to have diversity training in order to better serve their students and prepare them for the adult world.

There are many conceptual frameworks in the realm of education about how to teach teachers to address the multiple identities that students bring to the classroom. Some of those conceptual frameworks include: culturally relevant pedagogy, social justice education, democratic education, critical pedagogy, and multicultural education. These frameworks are built from the foundation of teaching for social justice. The objectives and goals of the previously listed frameworks are “frequently intertwined and overlapping” (Dover, 2013).

#### *Culturally Responsive/ Relevant Pedagogy*

Culturally relevant pedagogy is a framework that uses the personal experiences and cultural knowledge of the students within the classroom as the center of the curriculum. This requires teachers to take on the perspective of another to learn the cultural norms and understand the value in the diverse racial, ethnic, and language makeup in the classroom. Two examples of culturally responsive/relevant pedagogy are:

- Students can learn about weather by using their culture as seen within myths,

folklore and family sayings to teach the scientific concepts of weather. By using some of the students’ cultural backgrounds, a closer connection and better understanding to the scientific content can form (Irvine, 2009).

- For social studies, a teacher can create a voter education project by helping students “analyze and report voting patterns in their neighborhood” (Irvine, 2009).

#### *Social Justice Education*

Social justice’s framework has a strong emphasis of building social awareness for students through the lens of power and privilege. Through that lens, students will critically examine how opportunities are not readily available for every individual, how oppression is found on an institutional and personal level, and what can be done to create social change. The teacher fulfills the role of an advocate by acknowledging the social, political, and economic realities that students and their parents encounter (Bemak & Chung, 2005).

#### *Democratic Education*

In the democratic education framework, the curriculum is enriched with the values of justice, respect, and trust with a goal of creating a community of equals by allowing students’ ideas and opinions to be equal to the teacher’s (Waghid, 2014). Democratic education can be embedded in the creation of policy groups such as youth advisory councils, student councils, student-teacher-administrator committees, and students leading reform efforts within their schools and communities.

#### *Critical Pedagogy*

Critical pedagogy details the examination of the power that marginalized groups experience compared to whites. The goal of this framework is to equip students with the tools to address inequalities in their environments to critical pedagogy in the context of a classroom. It works on a continuum and encourages students to move toward action and human agency “by applying agency through critical thinking in the classroom, then through individual social action, and finally through group social action” (Marri, 2005).

### *Multicultural Education*

Multicultural education focuses on creating equal opportunities for learning despite race, class, gender or exceptionality. Using the United States as a foundation, multicultural education requires teachers and students to dive into dismantling their “attitudes, beliefs, feelings, assumptions about U.S. society and culture” (Banks, 119). Though dismantling, teachers are able to make students conscious of the strengths and the contributions of diverse individuals within the United States’ context.

Multicultural education goes beyond content integration or an additive approach. With an additive approach, educators tend to “highlight an ethnic or cultural group invention, and discovery or contribution” (Baptiste & Key, 2001, p. 2) without changing the curriculum. Multicultural education in contrast helps educators see that content integration—say, putting content about Mexican Americans or African Americans in the curriculum—is important, but that it’s only a first step toward addressing diversity. The five dimensions of multicultural education are: (1) content integration, (2) knowledge construction (3) equity pedagogy (4) prejudice reduction, and (5) empowering school culture and social structure (Banks, 1998). Due to its multi-dimensional approach, the focus of my study is examining how teachers are trained to address diversity within teacher preparation programs using multicultural education as the main conceptual framework.

## **METHODS**

Because definitions and implementation of multicultural education vary widely, through this study, I investigated the following research questions: “What is multicultural education?” “How are teaching preparation programs approaching multicultural education,” and “What does multicultural education look like in the classroom?” I conducted 9 in-depth phone interviews with college professors. I decided to do a comparative study by interviewing faculty members to see how they understand multicultural education and what they do to prepare pre-service teachers in teacher preparation programs. In order to gather

unfiltered feedback about faculty members’ different preparation programs, I informed the interviewees that their identifying information would be kept confidential.

### *Population*

I began by identifying universities and colleges with Teaching Fellow Programs. Universities and colleges for the study were identified through Center for Educator Recruitment, Retention and Advancement (CERRA). Out of the 14 universities and colleges with a Teaching Fellow Program, nine met the criteria for the research study: (1) research interest in multicultural education, (2) experience with teaching a course for multicultural education or a related course about diversity. Faculty members were chosen based on their biography and their listed research interest. I then narrowed my pool of potential interviewees to faculty at those universities and colleges who met the two criteria. I contacted potential participants through an email requesting their participation in the study. I attached a consent form detailing the study and whether the participants were willing to be tape recorded for the semi-structured interview. Out of the nine eligible universities and colleges, five universities and colleges chose to participate.

### *Interviews*

My interviews were semi-structured. This allowed me to form an understanding about what multicultural education looks like within teacher preparation programs in South Carolina from the unique perspective of the faculty member. The open-ended questions allowed the faculty members that were being interviewed the freedom to elaborate on each question and provide additional information that helped me better understand the topic in discussion. Interview questions were created based upon doing an analysis of the existing literature. The primary interview questions were as follows:

- Are strategies for multicultural teaching an explicit portion of undergraduate teacher preparation programs?
- Are there any discussions and self-evaluations of pre-service teachers to identify their own racial, cultural, religious and sexual orientation biases

before they are placed in their full-term internship?

- Where do majority of teachers in your college of education seek employment after graduation?
- How do you faculty members define multicultural education?

Each interview was tape recorded to ensure accuracy and was transcribed after the interview. In addition to the interview, faculty members were asked if they could provide a syllabus for the class they were teaching that had multicultural principles.

### FINDINGS

Using the Multicultural framework, Five Dimensions of Multicultural Education, the following dimensions were present: content integration, knowledge construction, and prejudice reduction within South Carolina universities and colleges that were interviewed. Equity pedagogy and empowering school culture and social structure were two dimensions that were not met. Content integration was met by the five universities by the required literature that professors had students reading, writing assignments, and conversations that were structured into the syllabus to challenge the ideas and opinions that they brought into the classroom.

Bank's Five Dimensions of Multicultural Education	South Carolina's Colleges/Universities
1. Content Integration	Present
2. Knowledge Construction	Present
3. Equity Pedagogy	Not Present
4. Prejudice Reduction	Present
5. Empowering School Culture and Social Structure	Not Present

**Table 1:** A chart depicting if Bank's Five Dimensions of Multicultural Education was present in South Carolina's colleges/universities.

Knowledge construction was present because the professors at the five universities were intentional about the curriculum that they were teaching. Material was introduced as the student's ability to critically examine their own experience, compared to what is being manifested in society and their readings. This process of thinking provided students with a starting point to start thinking about implicit cultural assumptions that could be within the classroom curriculum. Equity pedagogy was not present within any of the five universities because there were not any readings or discussions about how teachers can modify their curriculum through cultural competency to meet the racial, cultural, ethnic, and gender groups within the classroom. Equity pedagogy is different from learning about diverse learners because the family and community culture of the student is being discussed rather than the learning style of the student, such as, tactile, auditory, kinesthetic or visual learner.

Prejudice reduction was present because the classroom discussions and the required written reflections were focused on the teacher's racial attitudes and how that can impact the students as well as how the students' racial attitudes can affect the classroom environment. Yet it did not move past discussion and written reflections. There were no mentioned or planned opportunities for students to create a tangible plan or learn about strategies to create a culturally competent classroom. Lastly, empowering school culture and social structure was not present and that could be contributed to the lack of time and room within the curriculum for teacher preparation programs. The students were primarily freshmen and sophomores. At this dimension, everyone involved with the education process, from administrators to the parents, are promoting a multicultural education. To reach this level, the other four will have to be beyond the emerging stage.

### IMPLICATIONS

Teacher preparation programs are stretching themselves to meet the growing demands of high quality teachers. The changes that have been made to various teaching

programs include raising admission requirements, recruiting more students from STEM fields to become teachers, and improving the curriculum to include more field experience (U.S. Department of Education, 2014). Even with the mentioned improvements of teaching programs, there is still not a space being made to include multicultural education beyond the “rhetoric around inclusivity and multicultural understanding (especially in relation to popular notions of globalization and internationalization)” (Lam, 2015) as part of the teacher preparation process. The reason why we must go beyond the common rhetoric of “inclusivity and multicultural understanding” is because the classroom is not a utopia. It does not exist in its own world; it is a smaller environment that children grow, learn, and develop in preparation for a much larger environment—the world. The discussions of race, social class, gender, religion, sexual orientation and privilege are happening outside of the classroom and affecting people in harmful ways. Students need to learn how to engage in a healthy dialogue about those issues and learn how to dismantle the –isms that have been embedded within social policy, the judicial system, employment, and other pathways to access.

Requirements for educators are increasing with each year. As the expectations increase, universities and colleges are trying to get ahead by loading up programs with additional classes to prepare pre-service teachers with even more. However, the more usually do not include multicultural education. Universities and colleges do not need to increase, but enrich. By taking a closer look at the essential readings of offered courses, a deeper analysis can be added to classroom discussion to see if different races, ethnicities, religions, genders, nations, and sexual orientations are represented. Creating an inclusive framework to process information can better assist the conversation within the classroom—especially when it is challenging and uncomfortable.

## REFERENCES

- Bemak, F., & Chung, R. C. Y. (2005). Advocacy as a critical role for urban school counselors: Working toward equity and social justice. *Professional School Counseling*, 196-202.
- Baptiste, H. P. & Key, S. G. (2001). Celebrating cultural diversity: Science learning for all. *NSTA Press*, National Science Teachers Association.
- Banks, J. A. (1994). *An introduction to multicultural education*. Boston: Allyn and Bacon.
- Banks, J. A. (1998). The lives and values of researchers: Implications for educating citizens in a multicultural society. *Educational Researcher*, 4-17.
- Center for Educator Recruitment, Retention and Advancement (CERRA). (2015). *Teaching Fellows Data*. Retrieved from: <http://cerra.org/teachingfellows/data.a.spx>
- Dover, A. G. (2013). Teaching for social justice: From conceptual frameworks to classroom practices. *Multicultural Perspectives*, 15(1), 3-11.
- Forshay, A. (1991). “The curriculum matrix: Transcendence and mathematics.” Retrieved from [http://www.ascd.org/ASCD/pdf/journals/ed\\_update/eu201207\\_infographic.pdf](http://www.ascd.org/ASCD/pdf/journals/ed_update/eu201207_infographic.pdf)
- Gorski, P.C, Davis, S. N., & Reiter, A. (2012). Self-efficacy and multicultural teacher education in the united states: The factors that influence who feels qualified to be a multicultural teacher educator. *Multicultural Perspectives*, 14(4), 220-228.
- Irvine, J.J. (2009, Fall). Relevant: Beyond the basics. *Teaching Tolerance*, 36,41-44.
- Lam, K.D. (2015). Teaching for Liberation: Critical reflection in teacher education. *Multicultural Perspectives*, 17(3), 157-162.
- Marri, A. (2005). Building a framework for classroom-based multicultural democratic education: Learning from three skilled teachers. *The Teachers College Record*, 107(5), 1036-1059.

- Spodek, B., & Saracho, O. N. (2014). *Handbook of research on the education of young children*. Routledge.
- U.S. Department of Education, National Center for Education Statistics, Common Core of Data (CCD). (2014). *State nonfiscal survey of public elementary and secondary education, 1998-99 through 2011-12; and national elementary and secondary enrollment projection model, 1972 through 2023*. Retrieved from [https://nces.ed.gov/programs/digest/d13/tables/dt13\\_203.60.asp?current=yes](https://nces.ed.gov/programs/digest/d13/tables/dt13_203.60.asp?current=yes)
- U.S. Department of Education, (2014, November 25) *U.S. department of education proposes plan to strengthen teacher preparation*. Retrieved from <http://www.ed.gov/news/press-releases/us-department-education-proposes-plan-strengthen-teacher-preparation>
- Waghid, Y. (2014). *Pedagogy out of bounds: Untamed variations of democratic education* (Vol. 61). Springer Science & Business Media.



# How Do Family Background and Self-Esteem Affect an Individual's Perception of Gender-Role Portrayal in Online Advertisements?

Cera Crowe  
Aimee Meader, Ph.D. (Mentor)

“The image of myself which I try to create in my own mind in order that I may love myself is very different from the image which I try to create in the minds of others in order that they may love me.” —W.H. Auden

## ABSTRACT

The purpose of this study is to further understand the relationship of family background and how it affects self-esteem and the perception of gender roles in online imagery. This study focuses on how our history serves as a lens to see gender roles. The schema theory, created by Robert Axelrod, is a model suggesting that people have a “pre-existing assumption about the way the world is organized” (Axelford, 1974). Furthering this theory is Bem's (1981) Gender Schema Theory, which proposes that one's sexual self-concept affects how one structures items in memory. These theories, applied to the understood roles and activities that we see our parents perform, should relate to how we see people in the media take on certain roles and activities in online advertisements. The method for collecting data is a survey broken down into questions of demographics, family history, self-esteem, and ten randomized advertisements portraying traditional, decorative, and non-traditional gender roles for both men and women. If we can begin to understand the relationship between family background and advertisement effectiveness, then advertisers can see the real cultural values and changing gender-role identities in consumers.

## INTRODUCTION

The schema theory, created by Robert Axelrod, is a model (see Figure 1) suggesting that people have a “pre-existing assumption about the way the world is organized” (Axelford, 1974). In relation to advertising, information is sent and then received by an audience. The audience interprets this message based on information currently available to the audience such as past experience, repetition of outcomes, and relationship to currently understood “truths.” This theory, applied to the understood roles and activities that we see our parents perform, is expected to correlate to how we see media personnel take on certain roles and activities in online advertisements. This study is unlike most published studies related to gender roles and self-esteem in advertising because it does not focus on body dissatisfaction; it instead focuses on why our family history makes us see gender roles the way we do.

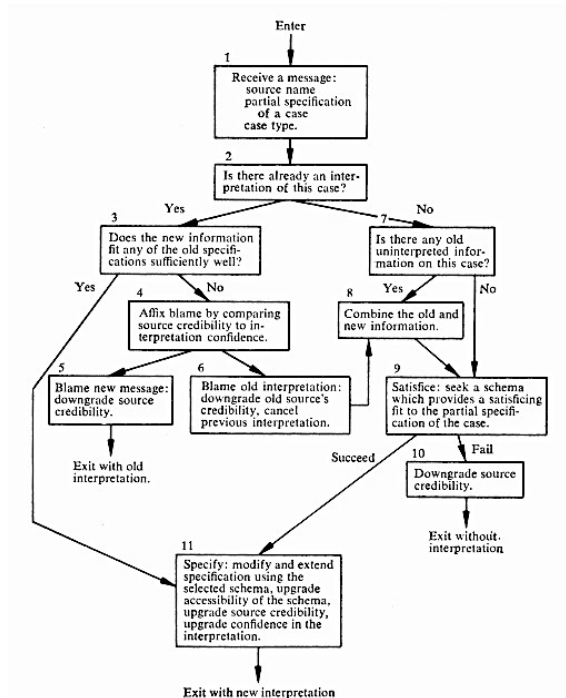

Figure 1. Process Model for Schema Theory.

### *Online Advertising*

Online advertising serves a variety of purposes including offering worldwide coverage of advertising messages and projecting corporate identity. Examples of online advertising include banner ads, search engine result pages, social-networking ads, email spam, online classified ads, pop-ups, contextual ads, spyware, and targeted advertising based on your search history (Janssen, n.d.). The difference between online advertising and other forms of media (such as print and cable television), is the promotion of product information without any geographical limitations. With all forms of advertising comes the creation of “consumer culture.” Culture refers to the whole set of meanings, beliefs, attitudes and ways of doing things that are shared by some homogenous social group and are typically handed down from generation to generation. With consumer culture, advertisers are given the power to create a culture in which consumers see themselves. Consumer culture has been defined as a society in which human values have been “grotesquely distorted so that the commodities become more important than people or, in an alternative formulation, commodities become not ends in themselves but overvalued means for acquiring acceptable ends like love and friendship” (Schudson, 1984, p. 7). This definition becomes increasingly true when the method of human interaction is now largely done from behind a screen. Digital devices are increasingly intersecting with what we understand as our human identity. When creating consumer culture, “advertisers have almost always relied on stereotypes to establish rapport with consumers and move on to more important information about the product or service being advertised. It is efficient for advertising to use gendered stereotypes because the scene becomes immediately set” (Sheehan, 2014 p. 100). Online advertising allows advertisers to use click-through rates and HTTP cookies to see what consumers are interested in. These tools allow advertisers to have more efficient data when creating target markets. When setting the scene, advertisers operate with a target audience in mind when selling certain types of product. Targeting, or relating a product to a

certain demographic, is the basis behind the role-product congruity theory. The role-product congruity theory suggests that advertising effectiveness can be increased when appropriate models are used (Sheehan, 2014 p. 103). This means creating a gender-role, ethnicity, and an assumption of a cultural normalcy to the identity of a product or brand.

### *Gender-Role Portrayal*

Advertising generally operates on the appearance of binary sexes, or male and female individuals. Men and women are understood to be very different. The variations between the two genders include body characteristics, role in the home, role in child rearing, and the expectation of societal position. Gender stereotypes are general beliefs about sex-linked traits and roles, psychological characteristics, and behaviors describing women and men. Gender identities are often socially constructed, and advertising proposes lifestyles and forms of self-presentation that individuals use to define their roles in society (Giddens, 1991; Wolf, 1991). Gender roles have changed socially and economically since the 1940s. Around the world, women are delaying marriage to increase their educational and career opportunities (Sheehan, 2014 p. 90). In 1940, women comprised about 20% of the workforce in the United States, while today that percentage is 57% (U.S. Department of Labor, 2015). Men with children under 18 years old have 93% participation in the labor force, while women with children under 18 years old have 70% participation in the labor force (U.S. Department of Labor, 2015). Although women are more represented in the workforce than in previous decades, the historical role of homemaker still lingers in the media. Deciphering these gender differences and characteristics is not an easy task for media creators. Advertisements where people are portrayed, typically can be categorized into four groups (and sometimes hybrids of multiple groups) for both men and women: traditional, decorative, non-traditional, and neutral.

- Traditional is the expected stereotypical role of a gender.

- Non-traditional is the unexpected or unforeseen role of a gender.
- Decorative is when a gender is shown concerned with physical attractiveness or sex objects.
- Neutral is when men and women are portrayed as equal.

#### *Women*

Traditional role portrayal for women is that of a dependent home-maker and housewife (Plakoyiannaki, 2008; Sheenan, 2014 p. 92). “Advertising has firmly held on to this portrayal of women as homemakers and uses this imagery to promote all types of products from household goods to computers and automobiles” (Sheehan 2014 p. 91). The implications associated with the female traditional gender role portrayal is that of the male non-traditional gender role portrayal. The frequency of imagery affiliated with females as the head of child rearing and homemaking can cause men to feel as if they are inadequate as partners.

Decorative role portrayal is when a woman is “shown concerned with physical attractiveness and sex objects” (Plakoyiannaki, 2008; Sheenan 2014 p.98). Displaying women in a decorative role has been the subject of numerous studies related to body dissatisfaction and depression. The cult of beauty is age old and clinging steadily to every generation. In fairytales, good women are pretty and evil queens are old and ugly. Physical attractiveness is taught to children as a symbolic representation of internal good. The current generation has an obsession with appearance like no other generation preceding it. People no longer simply worry about our physical appearance in the presence of others, but also on our social media and other accounts. Our concern for appearance is beyond just what we think we look like, and how others see us— but now it’s the “idea” of us. A study of advertising globally (Peak et al., 2011) found that women are four times more likely to be presented visually (without a speaking role) than males. The fact that women tend to be portrayed in decorative roles more than men suggests that advertisements do not render a realistic

depiction of the female gender role (Paff & Lakner, 1997). When decorative roles and sexual imagery is used, advertisements often include nonverbal cues as an indication that women lack authority and possess less power than men (Simmons, 1986). Body language and size relationship often suggest that women are submissive toward products, while men are pictured in control (Goffman, 1979). Take for example this Gucci advertisement:



The implications of this role portrayal make it harder for women to be seen in the non-traditional role, traditional role, and neutral role. If a woman is frequently shown as a sex object and concerned with physical attractiveness, then it possibly undermines other roles she may strive to be.

Women in non-traditional roles are depicted as career-oriented, doing non-traditional activities, and as voices of authority (Plakoyiannaki, 2008). Their body language isn’t submissive or allocating their power to any person or product. Current films and television attempt at portraying strong female characters but falter by adding in sexuality or dependency. The female protagonist in modern cinema is becoming more common (The Hunger Games, 2012; Insurgent, 2015; Black Widow from the Avengers, 2012). Yet the amount of male lead roles with heroic capabilities greatly outnumbers those with women lead roles. If women are portrayed as capable and strong, they are usually coupled with a strong male partner or group of

males. The relationship is often sexually charged.

Neutral role portrayal is when a woman is portrayed as equal to a man. This role is particularly hard to determine to an untrained eye because one must look at size relationship, body language, text, and activity in terms of equal representation to that of the man pictured. Advertisements that target the entire world with an enveloping message related to concepts of humanity do this really well. An example of this is Coca-Cola's campaign on "Open happiness." Everyone can identify with happiness— men and women of international ethnicities were portrayed.

### *Men*

Traditional role portrayal of men is the breadwinning husband in a suit who works a daytime job. Males are usually shown with economic, physical, or societal authority. The idea of the male as the protector is as timeless as the damsel in distress. A man is portrayed as hardened, anchored, and resolute in his course of action. It is expected of the man to protect and provide, and not show vulnerability. This is a stereotype that deprives men of their humanity. It should not be abnormal to see a human being express vulnerability, uncertainty, fear, or sadness.

Like female decorative role portrayal, male decorative role portrayal is also concerned with physical attractiveness and sex objects. The difference is that rather than being submissive to the person or product, the male holds power over the person and product. Erving Goffman, a leader in verbal cues, says that power can usually be located in the body language (Goffman, 1979). Examples of this include the stance of the male, gaze, and grip. While a female in the decorative role is shown with an averted gaze (licensed withdrawal), the male is shown with an anchored forward gaze. Fairytales again serve as an excellent example of decorative roles. The prince is expected to be handsome, strong, and courageous.

Non-traditional role portrayal for men is that of a confident child caretaker, doing housework, and/or depicted as vulnerable. Some advertisements *attempt* equality in parenting by presenting images of fathers who

are "childish but loveable goofballs" (Crain, 2001), irresponsible fathers and lazy foolish husbands (Sacks & Smaglick, 2008). This could be a societal inconsistency if such images are not balanced with other images showing men as confident and capable in traditional house making situations (Sheehan 2014, p. 94).

Neutral role portrayal is when a man is portrayed as equal to a woman. This role is particularly hard to determine because you must look at size relationship, body language, text, and activity in terms of equal representation to that of a woman.

### *The Modern Family and Self-Esteem*

Targeting an audience is a key factor in advertising. So it is important for advertisers to understand the changing relationships happening amongst consumers and families. The traditional family is the "natural reproductive unit" of mom, pop, and the children all living under one roof. It is a social construct that varies from culture to culture, and overtime, the definition changes within a culture (Stephens, 2012). That is exactly what is happening in the United States. Variations of the non-traditional family are increasing. A non-traditional family is any family unit outside of the traditional nuclear family. This includes but is not limited to a single parent family, divorced parent family, step family, widowed-parent family, cohabiting couple with children, same sex family, a relative serving as a parent that is neither the mother nor father, and a single person who chooses adoption (Stephens, 2012). A very notable trend is that marriage is decreasing over time (Figure MS-1a and Figure MS-1b). This could possibly be because women are choosing education and career goals over marriage, relationships are facing new challenges, or cohabiting couples are content without further commitment. The decrease in marriage trends could also factor into why the two parent living arrangements of children is decreasing over time (Figure CH-1). Thirty-two percent of families in the United States, as of 2013, are single parent families (Figure TF-1).

Family structure gives us something to relate the world to and helps us understand who we are. "Personality theorists who are concerned with constructs involving the self put great

importance to parent-child interaction in the development of self. This notion follows from such general ideas as these: (a) the self-concept is a learned constellation of perceptions, cognitions, and values. (b) An important part of this learning comes from observing the reactions one gets from other persons. (c) The parents are the persons who are present earliest and most consistently. For this reason, and because of the child's dependence on them, the parents have a unique opportunity to reinforce selectively the child's learning" (Wylie 1961 p. 121). Self-esteem is an overall evaluation of one's worth or value. American families are changing, and by association, so are attitudes toward ourselves and gender responsibilities.

Figure CH-1  
Living arrangements of children: 1960 to present

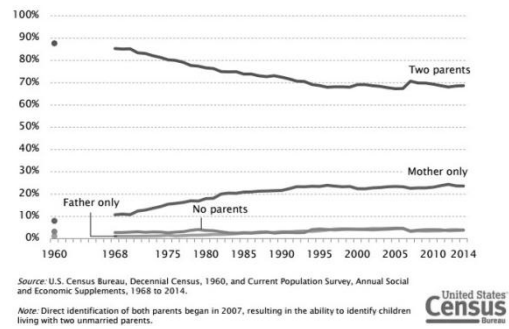

Type of families with children under 18, 2013 annual averages

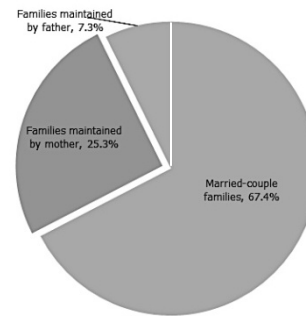

Figure MS-1a  
Men's marital status: 1950 to present

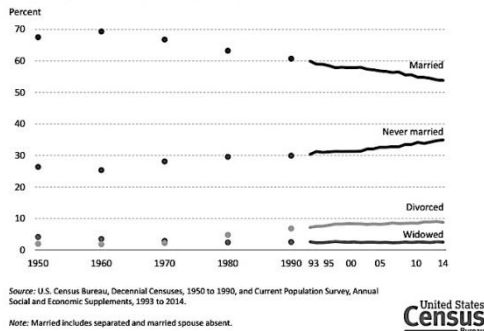
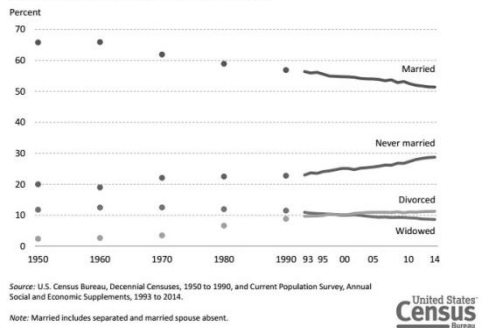

Figure MS-1b  
Women's marital status: 1950 to present



## METHODOLOGY

To address the research question, individuals' family history selection and self-esteem scores are compared to their advertisement effectiveness score. To collect data, an online survey was created using Qualtrics. The survey first asks basic demographic questions (race, gender, age, marital status, family background) and then uses Rosenberg's self-esteem scale. Thirty-seven participants were from a traditional family and fifteen participants came from a non-traditional family. Forty-one participants were female and eleven were male. Because we did not want race relatability to affect advertisement effectiveness, there will be two versions of the following section of the survey (that are as identical in content as possible), one with Caucasian representative ads and another with African American representative ads. Each gender role portrayal was matched in content in both surveys. Participants who selected other racial groups (besides Caucasian and African American) were directed to the end of the

survey. A lot of time was invested in content analysis of advertisements and it was not within the means of this study to create a survey for each race. This decision was also made with expected participation audience in mind. Qualifying participants were then shown ten advertisements randomized— three male advertisements (traditional, non-traditional, and decorative), three female advertisements (traditional, non-traditional, and decorative), one neutral advertisement (male and female portrayed as equal), and three decoy advertisements to hide the nature of the survey. A majority of these advertisements (18 out of 20) are borrowed from fifty companies (cited and manipulated to meet Fair Use copyright limitations) listed on Forbes “The World’s Most Valuable Brands” during the month of May 2015. The remaining two advertisements were the female non-traditional gender role portrayal. Because they were not found represented on websites belonging to “The World’s Most Valuable Brands,” they were created using Adobe Photoshop.

Using content analysis, hundreds of advertisements were looked at and coded into (a) gender role portrayal and (b) targeted race of audience. Only the advertisements that fit each gender role portrayal most exclusively were used in the final survey. Each advertisement is rectangular and shown for precisely ten seconds, as rectangles constitute the bulk of online advertising and are used by almost all advertising agencies and corporations employing electronic media. Ads other than neutral and decoy ones only have one adult pictured. Advertisements were only selected if the product advertised was global, as captured through its international reputation. After each advertisement, a general question about content and reaction questions related to advertisement effectiveness were asked (enjoyment, trustworthiness, and relatability).

*Data Analysis*

Data was analyzed using mixed ANOVA in SPSS Statistics.

A 2 (Family Type: Traditional, Nontraditional) X 2 (Gender: Men, Women) X 3 (Role: Traditional, Nontraditional, Decorative) X 3

(Rating: Enjoyment, Trustworthiness, Relatability) Mixed ANOVA with Family Type as the only between-subjects variable.

The four way effect (Gender X Role X Rating X Family Type) was not significant,  $F(4, 204) = 0.57, p > .05$ . None of effects involving family background were significant, all  $F_s < 1.15, p_s > .32$ .

The Gender X Role X Rating interaction was significant,  $F(4, 204) = 3.28, p < .05, \eta_p^2 = .06$  (see Figures 1, 2, and 3).

All effects that did not involve family background were significant, all  $F_s > 5.83, p_s < .05$ .

**RESULTS**

**Traditional Role**

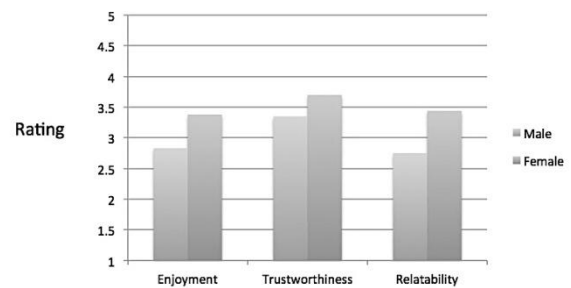

Women shown in traditional roles are rated higher than men in traditional roles in enjoyment, trustworthiness, and relatability.

Trustworthiness is rated higher than enjoyment and relatability for both men and women.

**Non-Traditional Role**

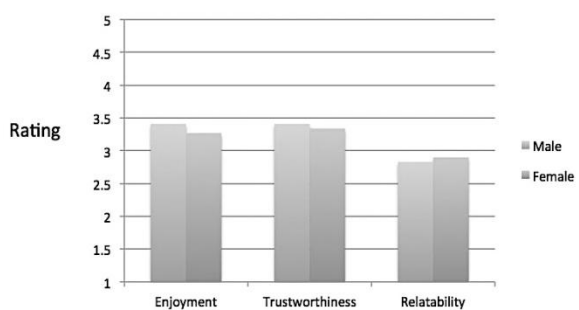

Enjoyment and trust are rated higher than relatability for both men and women when shown images of people in the non-traditional gender role.

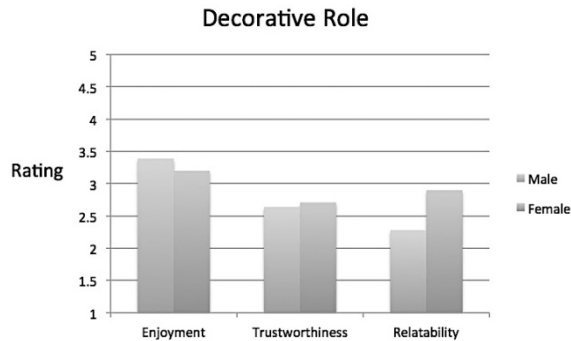

Overall, decorative role portrayal is less favored than traditional and non-traditional

Participants stated they relate themselves and their experiences to the images of females portrayed in decorative roles, more than males in decorative roles.

### DISCUSSION

Family background did not factor into the perception of gender roles in imagery. This could be the reality of how people process advertisements, or it could occur because of a low sample size in participants or advertisements. There are many factors that go into measuring the influence that our parents have on our decision making process. The survey could be improved by measuring this effect more adequately. Another explanation could be that people self-monitor more when interacting with advertisements because they are so accustomed to them. Although frequency and time was measured on each ad while taking the survey, participants come desensitized to advertisements. Furthermore, the results may have occurred because of the restriction to a two-dimensional, ten second image. Online advertisements may not allow for memories and relationship recognition like other forms of media.

Self-esteem did not fluctuate significantly between traditional and non-

traditional family types. Family structure could not be the significant factor here, but instead the quality of the relationship with the parental role and the amount of interest they invest into developing a child. Alternatively, self-esteem greatly operates independently of family structure.

The data showed the decorative role portrayal is less favored than traditional and non-traditional role portrayal. Decorative ads challenge societal norms of what should or should not be exposed in terms of body parts. This is an example of Schema Theory at work. We know what is acceptable in society and we react accordingly. It is particularly interesting that decorative ads are so frequently presented to the public, yet they are less favored. It is often said that “sex sells” but according to the data, this may not be the case.

Participants stated they relate themselves and their experiences to the images of females portrayed in decorative roles, more than males in decorative roles. This could be a response created by the more frequent images of females in decorative roles in comparison to men in the public. The relevance of this information is that men and women relate themselves personally with images of women portrayed sexually more than they do with men. The implications of this are both positive and negative. First, it could show that women are satisfied enough in their sexuality and body to relate their life to a decorative ad. Secondly it could mean that women and men are desensitized to the female figure more than the male figure. Also it could show a societal neglect towards men when expressing their sexuality.

### FUTURE PLANS

From my study I learned that our upbringing does not affect our immediate measured reaction to gender roles in imagery. Each variable examined, self-esteem, family influence, and gender role, proved to be very complex and are key defining components to human nature. The study was ambitiously interdisciplinary and that is the nature of research in communications and the social sciences. If I were to continue this study, I would perform content analysis of ideas and

campaigns in actual advertising agencies. I would cross reference that information with the background and self concepts of the designers themselves. They have more notable and measurable feelings towards their work than an audience seeing an image for mere seconds. These agencies could also provide me with data on how many people they reach. In the meantime, I am putting this project on hold. In the summer of 2016, I will begin studying media's relationship with the environment and sustainable business practices under the guidance of Dr. Padmini Patwardhan. If you would like more information about me, my study, or my future plans, please feel free to contact me at [crowec2@winthrop.edu](mailto:crowec2@winthrop.edu).

### SOURCES

- Axelrod, R. (1974). Schema Theory: An Information Processing Model of Perception and Cognition. *The American Political Science Review*, 1248-1248.
- Bem, S. (1993). *The lenses of gender: Transforming the debate on sexual inequality*. New Haven: Yale University Press.
- Copyright Law of the United States of America. (n.d.). Retrieved May 2, 2015, from <http://www.copyright.gov/title17/92chap1.html#113>
- Crain, R. (2001, March 26). Husbands are boys and wives their mothers in the land of ads. *Advertising Age*, 72, 22.
- Giddens, A. (1991). *Modernity and self-identity: Self and society in the late modern age*. Stanford, Calif.: Stanford University Press.
- Goffman, E. (1979). *Gender advertisements*. Cambridge, MA: Harvard University Press.
- Paff, J. L., & Lakner, H. B. (1997). Dress and the female gender role in magazine advertisements of 1950-1994: a content analysis. *Family and Consumer Sciences Research Journal*, 26(1), 29-58.
- Plakoyiannaki, E., Mathioudaki, K., Dimitratos, P., & Zotos, Y. (2008). Images of Women in Online Advertisements of Global Products: Does Sexism Exist? *Journal of Business Ethics*, 101-112.
- Rosenberg, M. (1989). *Society and the adolescent self-image* (Rev. ed., 1st Wesleyan ed.). Middletown, Conn.: Wesleyan University Press.
- Sacks, G., & Smaglick, R. (2008, April 14). Advertisers: Men are not idiots. *Ad Age*, 79, 44.
- Schudson, M. (1984). *Advertising, the uneasy persuasion*. New York, NY: Basic Books.
- Stephens, M. (2012). The Non-Traditional Family: An Introduction. *Rev Black Polit Econ The Review of Black Political Economy*, 27-29.
- Sheehan, K. (2003). *Controversies in contemporary advertising*. Thousand Oaks: Sage Publications.
- Simmons, J. M. (1986). Gender differences of nonverbal power cues in television commercials. In E. F. Larkin (Ed.) *Proceedings of the 1986 Convention of the American Academy of Advertising* (pp. R72-R76). Norman: University of Oklahoma Press.
- Wylie, Ruth C. *The Self Concept: A Critical Survey of Pertinent Research Literature*. Lincoln: U of Nebraska, 1961. Print.



# LGBTQ Emerging Adults: Their Experiences with Homelessness

Jesse Lee Grainger  
Brent Cagle, Ph.D. (Mentor)

## ABSTRACT

Using a qualitative method, this study explored the experiences of emerging adults (ages 18-24) who are LGBTQ and homeless in the Charlotte/Mecklenburg area of North Carolina. Emerging adults who are homeless and identify as LGBTQ are shown to have different health and safety concerns compared to peers. Because of these unique factors, researchers suggest these individuals require specific social services that cater to their needs. Nine face-to-face interviews were conducted which resulted in a total of 9 hours of collected data. In order to ensure that research results are as accurate as possible, grounded theorists suggest that one have at least fifty hours of collected data (Charmaz, 2006). Therefore, this study uses a grounded theory method as a guide to explore the experiences of emerging adults who identify as LGBTQ and are homeless. Questions in this study were designed to explore participants' experiences with community-based outreach services and their overall experience with homelessness. This paper addresses three major themes found within the data: unsafe shelter conditions for LGBTQ individuals, couch surfing, and resiliency. Participants who had access to organizations such as RAIN (REGIONAL AIDS INTERFAITH NETWORK) which provided social support systems, were in college, and living a healthy lifestyle. Data suggests that those with a strong social capital are more likely to be successful (in their definition of the word).

**Keywords:** LGBTQ, homelessness, emerging adults, couch surfing, resiliency, social capital

## INTRODUCTION

This paper examines the experiences of emerging adults who are LGBTQ and homeless using a qualitative method approach. In the beginning, I explore the fairly new concept of emerging adulthood, and how this theory can help to explain the transitional phase that these young adults undergo. Youth who are LGBTQ represent 40% of all homeless youth. Moreover, many of these youth who are "couch surfing" are not considered homeless because they are not "roofless." In the literature review I discuss the concept of couch surfing. Later, I discuss how couch surfing played a major role in many of the participants experiences with homelessness.

Emerging adults who identify as LGBTQ face many more challenges during this developmental stage than their heterosexual counterparts. This paper examines many of the risks that this population encounters; risks include: poor mental health, higher rates of substance abuse, higher chances of being physically, verbally, emotionally, and sexually

abused, and higher rates of HIV/AIDS. Nonetheless, many of these individuals remain resilient despite the added stressors that they face. These individuals rely on their strengths and strive to live life in the way they see fit.

Another major theme seen within this paper is the concept of resiliency; and how resiliency allows these individuals to become the person that they see within themselves. I also examined the differences between participants who had social support systems in place and those who did not and determined that, in many cases, social support in and of itself affected the individual's experience with homelessness. Lastly, I recount participants' experiences with shelters in the Charlotte/Mecklenburg area, and how these experiences oft' depict heinous and unsafe environments.

## LITERATURE REVIEW

### *Emerging Adulthood*

Emerging adulthood is a phenomenon that has only appeared in the last few decades.

Jeffrey Arnett proposed emerging adulthood as a new theory of development for the period that spans from late teens, through the twenties, with a focus on ages 18-25 (Arnett, 2000). The term “emerging adult” is generally characterized by “young adults” who live in developed countries, do not own a home, do not have children, and do not have sufficient income to become fully independent (Arnett, 2000). However, when using the term “young adult” we imply that adulthood has been reached. Arnett argues that because this group does not see themselves as either an adolescent or an adult, but somewhere in between, there must be a separate developmental theory in place for this group (Arnett, 2000). Emerging adulthood is a period of life that is culturally constructed and by no means universal. For instance, it is normal for those from Western cultures who have aged out of adolescence and into a more autonomous role, but have yet to enter into normative adulthood routines, to have more time to explore their options in life (eg. career, education, love & relationships). However, other cultures place a heavy value on “settling down” early. In America, emerging adulthood is defined as a period of exploration and the only period of life in which nothing is normative demographically (Arnett, 2000). For instance:

During adolescence, up to age 18, a variety of key demographic areas show little variation. Over 95% of American adolescents aged 12-17 live at home with one or more parents, over 98% are unmarried, fewer than 10% have had a child, and over 95% are enrolled in school (U.S. Bureau of the Census, 1997). By age 30, new demographic norms have been established: About 75% of 30-year-olds have married, about 75% have become parents, and fewer than 10% are enrolled in school (Arnett, 2000).

However, Arnett argues that in between these two periods, especially ages 18-25, a person’s age is not enough to predict demographic status in these areas. Because emerging adults have a wider variety of possible activities than individuals in other age periods, they are less likely to be “constrained by role requirements,” which makes their

demographic status unpredictable (Arnett, 2000).

As described by Arnett, emerging adulthood can be defined as an: age of identity exploration, age of instability, age of self-focus, age of feeling in-between, and age of possibilities (Arnett, 2000; Munsey, 2006). Freed from parents, young people are figuring out who they are and what they want out of school, work, and love. Many emerging adults will successfully traverse the confusing path into adulthood. However, because of a lack of financial resources, instability, and a multitude of possible paths to take, many will struggle along the way. Because of these struggles, Arnett argues that we need to expand our efforts as a society to help these young people navigate the transition into adulthood. LGBTQ emerging adults encounter far more struggles than that of their heterosexual counterparts. These young people face stigmatization when exploring life and forming a sense of “self” that is conceptualized around their sexual orientation. Fears of not being accepted by family and peers can sometimes lead these young people to feel guilty and often times self-blaming behaviors emerge as a result of not being accepted. Obviously, being homeless adds an extra burden on LGBTQ emerging adults who are trying to find their place in a world where they feel unwelcome. Many of these young people that live on the street have no family support simply because they identify as LGBTQ. Barriers such as lack of guidance, lack of education, and lack of services keep these young people from successfully crossing over the blurred lines of adulthood. Because of the self-awareness that is developed within the twenties and this age groups’ openness to change, Arnett argues that our efforts to help guide these individuals would pay off (Arnett, 2000; Munsey, 2006). “If you provide them with resources, they’re much more likely to say, ‘How can I improve my life?’” Arnett says (Arnett, 2000; Munsey, 2006).

#### *Disproportionate Statistics*

Youth homelessness is a pervasive problem seen in all parts of our country. In fact, approximately 1.7 million young people under the age of 24 call the streets of America

home. Current research suggests that roughly 40 percent of all homeless youth identify as Lesbian, Gay, Bisexual, Transgender, or Questioning (Ray, 2006). Considering that only 5 percent of the population identifies as LGBTQ, it is obvious that these youths experience homelessness in greater proportions than that of their heterosexual counterparts (Ray, 2006). According to a 2014 Point-In-Time count conducted in Charlotte, NC there are roughly 151 emerging adults between the ages of 18-24 who are homeless in Mecklenburg County (North Carolina Coalition to End Homelessness, 2014). Research indicates that 40% of these emerging adults identify as LGBTQ, which means that on any given day, it may be estimated that around 60 LGBTQ emerging adults are living on the streets in Charlotte, NC (Ray, 2006).

Furthermore, there is grounds to believe that the number of homeless LGBTQ emerging adults may be higher than we think; those who are “doubled up” or “couch surfing” do not fit the federal definition of chronic homelessness, which is defined as:

An individual who lacks housing, including one whose primary residence during the night is a supervised public or private facility that provides temporary living accommodations; an individual who is a resident in transitional housing; or an individual who has as a primary residence a public or private place not designed for, or ordinarily used as, a regular sleeping accommodation for human beings (Net Industries, 2015).

Since these individuals do not meet the federal definition of “homeless,” they are not counted, and many services are not provided for them (McLoughlin, 2012). Although there is a scarce amount of research on the subject of “couch surfing”, it is clear that this phenomenon has the potential to create similar problems as traditionally defined homelessness (McLoughlin, 2012).

Often times, emerging adults’ experiences of homelessness involves moving frequently between temporary living arrangements with local households, including friends, friends’ parents, extended family, and

acquaintances (McLoughlin, 2012). “Commonly referred to as couch surfing or hidden homelessness, this practice is defined as a type of ‘secondary’ homelessness (McLoughlin, 2012). Although these individuals are not “roofless,” (a term used to describe those who live on the streets), they do lack stable living arrangements and are forced to live from home to home. McLoughlin stated: “we might think of the couch surfing relationships these young people rely upon as distinctive, in that they are sourced from their own social connections and involve typically rent-free living arrangements” (McLoughlin, 2012, p. 522).

### *Risks*

Emerging adults who are homeless and identify as LGBTQ have greater safety and health hazards than that of their heterosexual counterparts. For decades, there has been a stigma attached to being associated with the LGBTQ community. From anti-gay marriage campaigns to laws allowing businesses the ability not to serve gay individuals, the LGBTQ community has witnessed pervasive discrimination which includes hate crimes that range from assault to murder. A vast percentage of LGBTQ emerging adults who have homes and social support systems in place still suffer from anti-gay discriminatory behaviors. According to Ford, (2013) lesbian and male drag queens often suffered frequent rapes and sexual assaults which were committed by officers in the 1950s and 1960s (Ford, 2013). Moreover, police were no help when LGBTQ individuals were beaten or raped by civilians. One of the most frightening cases of oppression seen within the LGBTQ community is job discrimination. There was once a time when LGBTQ individuals were seen as a threat to national security and could not be employed in government positions. To this day, in many states, an individual can be fired because of their sexual orientation. In fact, according to Sangha, a recent study of 6,500 transgender people found that 90 percent of the individuals surveyed indicated that they experienced harassment and mistreatment at work, or, to avoid such treatment, believed they were forced to hide

their identity as transgender (Sangha, 2015, p. 58). In addition, she reports that “nearly half of the transgender individuals surveyed reported they were fired, not hired, or denied promotion because of their gender (Sangha, 2015, p. 58).” Additionally, many LGBTQ individuals are denied housing because of their orientation or gender expression.

According to Friedman, “Federal fair housing laws, seeking to ensure equal access to housing, prohibit housing discrimination based on race, color, religion, national origin, sex, familial status, and disability (Friedman, et al., 2013).” However, the Fair Housing Act does not include sexual orientation or gender expression as protected classes. Homelessness is also a critical issue for transgender people; According to The National Center for Transgender Equality, “one in five transgender individuals have experienced homelessness at some point in their lives. Family rejection and discrimination and violence have contributed to a large number of transgender and other LGBTQ-identified youth who are homeless in the United States (National Center for Transgender Equality, 2015).” In order to break the cycle of homelessness that is so prevalently seen within this population, we must work to ensure that each person is treated fairly regardless of their sexual orientation or gender expression.

Given the statistics and the history of oppression seen within the LGBTQ community, it is apparent that LGBTQ emerging adults who lack a stable living environment and adequate social support systems will encounter more risks than their heterosexual counterparts. In fact, research suggests that these individuals are more likely to suffer from mental health issues, substance abuse issues, victimization issues, and engage in risky sexual behavior, which leads to higher HIV risks (Keuroghlian, Shtasel, & Bassuk, 2014).

#### *Mental Health*

Anti-homosexual attitudes and stigmatization of the LGBTQ community in Western culture has resulted in added stressors for members of this population. Due to lack of support and social isolation that stem from the

stigma attached to the LGBTQ community, many emerging adults who are homeless may internalize feelings of guilt and shame because of their situation. In fact, emerging adults who identify as LGBTQ and homeless are more likely than their heterosexual counterparts to have a current major depressive episode (41.3% vs. 28.5%), posttraumatic stress disorder (PTSD; 47.6% vs. 33.4%), suicidal ideation (73% vs. 53.2%), and at least one suicide attempt (57.1% vs. 33.7%) (Keuroghlian, Shtasel, & Bassuk, 2014).

#### *Substance Abuse*

Emerging adults who are homeless and identify as LGBTQ are more likely than their heterosexual counterparts to abuse crack, cocaine, and methamphetamines (Cochran, Stewart, Ginzler, & Cauce, 2002). In regards to survival, it is notable to keep in mind that these individuals experience substantially greater challenges on the streets than their heterosexual counterparts. Some researchers indicate that the higher rates of substance abuse seen within the LGBTQ homeless population may be a coping mechanism that is used to deal with the numerous stressors that they encounter. (Cochran, Stewart, Ginzler, & Cauce, 2002).

#### *Victimization*

Many studies suggest that LGBTQ emerging adults who disclose their orientation may receive furious and violent responses from family, community members, school employees, and peers (Saewyc, et al., 2006). Although some of these individuals leave home on their own because their families use abusive tactics to try to change their orientation, many are forced into living on the streets by unaccepting family members. LGBTQ runaways are much more likely than heterosexual runaways to have been sexually abused by caretakers or close family members (Keuroghlian, Shtasel, & Bassuk, 2014). In fact, 35% of females and 65% of males have dealt with violence in the past. Furthermore, once on the street, LGBTQ individuals face greater chances of being both physically and sexually victimized.

### *Survival Sex and HIV*

Emerging adults who are homeless have limited legal ways of supporting themselves, and often turn to survival sex as a way to survive on the street (Walls & Bell, 2011). Many studies suggest that homeless gay and bisexual males engage in survival sex at remarkably higher rates than their heterosexual male counterparts (Walls & Bell, 2011). However, when comparing the rates of lesbian and bisexual females to heterosexual females, there is minimal statistical difference in survival sex behaviors (Walls & Bell, 2011). Emerging adults who engage in survival sex are at an increased risk of contracting sexually transmitted infections. One study revealed that more GLB (gay, lesbian, and bisexual) emerging adults reported that they were diagnosed with HIV than their heterosexual counterparts (35.2% vs. 3.5%) (Rew, Whittaker, Taylor-Seehafer, & Smith, 2005). Although condom use can significantly lower chances of contracting sexually transmitted infections, many studies have found that homelessness is directly linked to decreased condom use in the LGBTQ population (Keuroghlian, Shtasel, & Bassuk, 2014). Studies suggest that decreased condom use may be a result of the inability to set stringent boundaries due to internalized depression, grief, poor self-esteem, purposefulness, and feelings of anxiety (Keuroghlian, Shtasel, & Bassuk, 2014). Furthermore, when engaging in survival sex, these individuals are more easily coerced into not using a condom by partners.

### *Resiliency and Social Support*

According to Chang et al., “Resilience is the ability to survive and thrive in the face of overwhelming life changes. Resilience is a dynamic process that is the outcome of positive adaption in the face of significant adversity, stress, or risk (Chang, Scott, & Decker, 2013, p. 39).” Resilience is an important factor that must be considered when examining the overall well-being of LGBTQ emerging adults, especially those who face homelessness.

Many studies have been conducted that show the weaknesses and negative aspects of young people who identify as LGBTQ;

however, few of these studies portray the strengths of the population. Even fewer studies have analyzed resiliency within the homeless “subculture” of this population. Even though this population encounters pervasive marginalization throughout their lives, they still exhibit a great deal of resiliency. In a recent article, Herrick et al. stated: “Self- acceptance of sexual minority status and integration of sexual identity into an overall self- concept are the first steps in combating the cultural onslaught that sexual minority youths are likely to experience, and these steps count as forms of resilience in and of themselves (Herrick, Egan, Coulter, Friedman, & Stall, 2014).” Basically, self-acceptance in and of itself is a form of resiliency because it allows these individuals to be comfortable with their selves and their identity, which according to Hershberger and D’Augelli, can create a buffer against the stressors that have an influence on mental health. Self-acceptance empowers these individuals to not only claim their identity, but to embrace it, which also creates a buffer against the stigmas that are attached with identifying as LGBTQ+.

LGBTQ young people often times feel isolated because of their sexual identity. They are often times rejected by family member and peers, which can cause internalized homophobia and shame (Doty, Willoughby, Lindahl, & Malik, 2010). Doty et al. terms this as “*sexuality stress*,” that is, additional stressors that are related to ones’ sexuality. Social support is a crucial protective factor needed by LGBTQ young people in order to develop positively. Social support can shield against a variety of stressors: victimization, parental conflict, and natural disasters (Doty, Willoughby, Lindahl, & Malik, 2010). Furthermore, evidence suggests that sexuality specific forms of social support may be particularly meaningful for LGBTQ young people (Doty, Willoughby, Lindahl, & Malik, 2010). Social support services, such as support groups, that link LGBTQ individuals with others who also have similar identities has been proven to be a crucial component in building resilience within this population (Ozbay, et al., 2007).

## METHODS

In order to ensure that research results are as accurate as possible, grounded theorists suggest that one have at least fifty hours of collected data (Charmaz, 2006). This study uses a grounded theory method as a *guide* to explore the experiences of emerging adults who identify as LGBTQ and are homeless. According to Charmaz, “grounded theory methods consist of systematic, yet flexible guidelines for collecting and analyzing qualitative data to construct theories ‘grounded’ in the data themselves” (Charmaz, 2006).

### *Study Design and Research Questions*

There were four major phases of this study: research advertisement, participant selection, one-on-one interviewing, and data analysis. Once my proposal was accepted by the Winthrop Institutional Review Board, I began the initial stage of promoting the study. Since this is a difficult population to locate, I enlisted the help of several agencies in the Charlotte/Mecklenburg area to advertise and promote the study. These agencies include: Regional Aids Interfaith Network (RAIN); The Powerhouse; Beatties Ford Road Family Counseling Center; and Carolinas Care. The staff at RAIN stepped up and helped me secure seven interviews within just a few weeks of receiving my flier. I asked each participant if they knew other individuals who met the criteria and may be willing to participate in the study. One participant was able to connect me with the Powerhouse who then connected me to Beatties Ford Road Family Counseling Center and Carolinas Care where I was able to find two other participants for a total of eight. Six participants were African American, one was Latino, and one Caucasian. Six were enrolled in college, one had a high school diploma but no college degree, and one had no high school diploma or college degree. Five of the participants were employed and three were not. Seven of the participants were HIV positive while one was HIV negative. The high number of participants with HIV can be attributed to the high number of referrals from RAIN (Regional Aids Interfaith Network). Seven participants were referred through the RAIN organization.

In order to take part in the study each participant had to meet certain requirements: They must identify as LGBTQ, be between ages 18-24, and have an experience with homelessness that lasted more than six months. Each interview took place in public settings, mainly at the organization that the participant had an affiliation with. However, two interviews were conducted at a meeting area in Johnson Hall, which is located on the campus of Winthrop University. Interviews were audio recorded and lasted between 15-45 minutes. Each participant was compensated with a twenty dollar VISA gift card for the interview regardless of full participation.

Mainly, the study focused on experiences that these individuals had with community-based outreach organizations. Because of many anti-LGBTQ policies and the history of oppression seen within the community that I discussed earlier, I initially based this study on the hypothesis that this marginalized population was receiving inadequate services that were a direct result of their sexual orientation. However, once the data collection process began I noticed that very few cases of inadequate service was based on direct discrimination. Instead, I found that there were limited out-reach programs that provided the specific services that this marginalized and unique population require. After this realization, I opened my questioning process up in order to better gauge what services are needed and how current services are lacking or excelling to meet the specific needs of this population.

### *Data Gathering Procedures*

During the initial interview, I asked participants to describe their situation in regards to how they first became homeless. From there I guided the conversation with a core set of open-ended questions that were designed to explore each individual’s unique experiences. Questions were designed in a way that would not influence participants’ answers in any way. They were neither positive nor negative in nature. I inquired about their experiences with out-reach services and asked them to share any experiences that were positive and negative. After discussing these experiences, I asked participants how these encounters might

influence future decisions to use or refer others to community-based outreach organizations. Once this was discussed and any other questions that I had were answered, I asked participants to tell me how they were currently doing so I could get a sense of what was presently going on their lives and if they have seen any improvement in their situation.

#### *Ethics*

In order to ensure that participation was completely voluntarily, I thoroughly went over an informed consent at the beginning of each interview, which was then given to participants. Participants were informed that this was a voluntary study in which they had the right to withdraw at any time. Participants were also informed that interviews would be audio-recorded and they had the option to stop recording at any point in the interview in which they felt uncomfortable. Throughout the interview process, I took every precaution possible to ensure the confidentiality of participants. Before starting and recording interviews, participants were given the option to choose a pseudonym, which would be used throughout the interview and transcription process. All audio files were secured in a locked file on a USB drive, which was stored in a locked container. Participants were provided with an informed consent statement and given the chance to ask any questions before starting the interview. Participants were also informed that they could request that audio-taping be stopped at any point during the interview and informed that they did not have to answer any question that made them feel uncomfortable. I also reinforced the fact that skipping any question or asking to turn off audio-recording would not impact their compensation.

#### *Data Analysis*

For this study, I used grounded theory as a guide to analyze and interpret data. I have summed up grounded theory using this quote by Strauss and Corbin:

If someone wanted to know whether one drug is more effective than another, then a double blind clinical trial would be more appropriate than grounded theory study. However, if someone wanted to know what it was like to be a

participant in a drug study, then he or she might sensibly engage in a grounded theory project or some other type of qualitative study (Strauss & Corbin, 1998).

Elements of grounded theory include: question formulation, interview transcribing, data coding, analytic memoing, theoretical sampling, and constructing theory. After formulating my questions and gathering data, I collected roughly six hours' worth of interviews, which I transcribed. Once the transcription process was over, I coded all of the collected data and developed concepts based on thematic similarities. According to Charmaz, "grounded theory methods consist of systematic, yet flexible guidelines for collecting and analyzing qualitative data to construct theories 'grounded' in the data themselves" (Charmaz, 2006). After looking at similarities within the data I worked with my mentor, Brent Cagle, to better ensure objectivity when analyzing data and constructing theories.

#### *Researcher Role*

Many research studies stem from the human drive to learn about and improve the unknown. Personally, I have faced many hurdles throughout my life that has led me to the field of social work and this particular study. Because of my experiences as a young gay male who has faced chronic homelessness, I wanted to study the experiences that other LGBTQ youth have with homelessness and the challenges that they encounter when trying to better themselves in order to get out of poverty. As an identifying gay male who has experienced homelessness as a young adult, there is the possibility that bias could have influenced the data gathering process. My experiences may have also influenced the way I analyzed and interpreted the data. As a social worker, and researcher, I must continually work towards my own self-awareness, and separate my experiences from that of the participants and the research project as a whole. Throughout this study I consulted with my mentor, Dr. Brent Cagle, to ensure that my work was as non-biased as possible.

## FINDINGS

Since this is exploratory research, these findings will begin to open doors for future research. When asked how they became homeless, participants gave three reasons: because they were kicked out of their home due to their sexuality (3), because they aged out of foster care (3), or because they left home by their own choice and could not support themselves (2). Three major themes caught my attention that I would like to explore more: unsafe shelter conditions for LGBTQ individuals, couch surfing, and resiliency. Couch surfing was the primary form of shelter for ALL participants, however 7 participants talked about living on the street, 3 talked about living in a car, and 3 talked about staying in shelters.

### *Unsafe Shelter Conditions*

Many of the participants spoke about Charlotte's shelters as being unsafe for LGBTQ individuals. Reasons for their concerns about safety varied. When I asked Tye to tell me about his experiences with the shelters in Charlotte, he laughed and told me:

Tye: "So, I mean, I didn't want to go to the shelter and different stuff like that because like I was raped and that's how I caught HIV due to being on the streets at a younger age. So, I mean, I was just house hopping."

When asked about his experience with homeless shelters Dave stated:

Dave: "Um, while I was there I didn't know what to do. I didn't have a bed ready. I didn't have ... I couldn't find no place to sleep. And I was scared to go to sleep because I was scared that something might happen to me. The homeless shelter I went to was on Lord Tryon and it has a reputation of people being raped."

Mario: "The shelter down there is dirty. There's a lot of people there and you got gay men, straight men. You get harassed by the people because you're gay. Or you get hit on by the older men you know, and stuff like that. Your stuff is stolen."

### *Couch Surfing*

Individuals who couch surf have no permanent address or stability, which makes it hard to get ahead. Mario describes couch surfing as:

Mario: "Like, uh, one minute be here then the next minute be there and change of address, change of work, change of school. Like, everything changed."

Quenn describes many different occasions in which he has had to couch surf. Quenn describes couch surfing as:

"Um, more couch surfing was, um, while, while I was with my mom, um, you know, going from couch to couch, you know, being on a couch in a track house, being on a couch in, uh, roach infested places ... Um, like I said, there was even a point of time where I wasn't on a couch. I was living in someone's shed."

Quenn also talks about living with twelve other people in a one bedroom apartment:

Quenn: "It was, oh my gosh, yeah there was one point in time where I lived in a one bedroom apartment with twelve other people. That was a, yeah, I'm not saying that was the worst experience I had because I have had worse but it was a really good struggle and it was, like I said, a one and only experience in my life that I could look back on and say "Hey, uh, I came out of it, how long did I make it through it but um, like I said, I think I was in the same situation or maybe I was still living with a friend girl or something like that, I can't remember cause there is so many times."

### *Resiliency*

I found that almost all of these participants had come out of their situation in positive ways. 6 out of 8 were enrolled in colleges, 7 out of 8 had some form of a diploma, and 5 out of 8 were employed. Furthermore, 6 out of 8 were no longer homeless at the time of the interview. These individuals' perseverance along with Community Resources played a major role in their resiliency.



Taye: “Um, I mean, I used a good bit of my support system, um, RAIN (Regional Aids Interfaith Network), you know, up here. Um, they helped me get into housing. I used different sources to try and get to where I'm at now. So I mean, as I look back over all of that it just made me stronger. And now I'm much more ahead in life at this point. I'm happy where I'm at now because I mean I done hit a whole 360.”

Mario: “Life is Way better, way better. I'm in school. I've been at my current location for three years now. Um, doing volunteer stuff here and trying to get the position working as peer navigator. Um, working, I work at Queens Pedicure, bar-tending and at the Baseball Park. So, everything is moving like ever since I got the house even though it was like my first step, that was like the root of the plant. It was like everything just grew from there. Because I had a permanent address. I could go to school and I can go to work from there and not worry about getting put out or worry about where is the next meal going to come here from.”

Quenn: “I feel like I'm doing pretty well, I've had a lot of great jobs, and, like I said, I'm still working on school and working at my current job. I'm moving forward in life and building as I go.”

#### *Limitations*

One particular challenge this study portrays, is a small and non-diverse sample size. However, the small sample size allowed in depth one-on-one interviews that is required for a qualitative study. Also, according to Charmaz (2006), in order to ensure that research results are as accurate as possible, grounded theorists suggest that one have at least fifty hours of collected data. Since I only had 6 hours of data, I would need conduct more interviews in order to reach saturation, and have conclusive results. Also, due to my inability to locate members of this population, many participants were referred to me through RAIN (Regional Aids Interfaith Network),

which is why there is such a high number of participants who are HIV positive. Moreover, since most of the participants were gay or bisexual African American males, who were HIV positive, this survey does not portray the entire LGBTQ population.

## **DISCUSSION**

Prior research has shown that LGBTQ young adults may face many challenges and stressors throughout their lives, more so than their heterosexual counterparts. Moreover, studies that examined LGBTQ young adults who are homeless reveal that there is a lack of services for these individuals across the nation. While there are agencies that offer specific services designed to assist this population, they are scattered throughout the region in a way that makes it hard for those without access to transportation to receive services.

Previous studies have shown that sexuality specific programs such as STD services that include HIV testing and counseling are a necessity for the well-being of these individuals. Many of my participants were referred from RAIN (Regional Aids Interfaith Network). RAIN is a local organization in Charlotte, NC that provides a plethora of services to the HIV/AIDS community. These services include: advocacy, case management, prevention education, and support groups. All participants who were referred to me from RAIN talked about how much of a positive impact the organization has had on their life. Moreover, these participants were also the very ones who maintained a strong sense of resiliency and were no longer homeless and living life in a way that they saw fit. Many of my participants had a strong sense of self-acceptance in terms of their sexual identity. It turns out, that these were the very ones who had social support systems in place. Also, all individuals who had a high sense of self-acceptance remained resilient, with low mental health issues, and higher achievement attainment. While I cannot conclusively say that this is because of RAIN, I will say that I think this had a lot to do with their progression. RAIN provided crucial social support programs that provided these individuals with the tools

they needed to become the person they saw within themselves.

Also, during my study I noticed that there was a lack of research dedicated to the “couch surfing” or “doubled up” phenomenon. An extensive search on many popular databases yielded just a handful of results regarding couch surfing. Many of these studies were conducted in other countries and have incomparable variables than those in America. In future research, I would like delve in and study this phenomenon in-depth.

While this study opened new doors for future research, such as couch surfing, it also revealed the deplorable shelter conditions in the greater Charlotte area. Participants described experiences involving rape, sexual and physical harassment, and theft; all participants seemed uneasy when discussing the living conditions of these shelters. According to section 6.01 of the NASW Code of Ethics:

Social workers should promote the general welfare of society, from local to global levels, and the development of people, their communities, and their environments. Social workers should advocate for living conditions conducive to the fulfillment of basic human needs and should promote social, economic, political, and cultural values and institutions that are compatible with the realization of social justice (Workers, 2008).

As social workers, and people, we have a responsibility to ensure the safety of those who are in our care. Moreover, we should be researching and advocating for better conditions for all who face homelessness.

## REFERENCES

- Arnett, J. J. (2000). Emerging Adulthood: A Theory of Development From the Late Teens Through the Twenties. *American Psychologist*, 55(5), 469-480. doi:10.1037//0003-066X.55.5.469
- Cagle, B. E. (2007). *Gay Young Men Transitioning to Adulthood: Resilience, Resources, and the Larger Social Environment*. Unpublished dissertation.
- Chang, V. N., Scott, S. T., & Decker, C. L. (2013). *Developing Helping Skills A Step-by-Step Approach to Competency*. Belmont: Cengage Learning.
- Charmaz, K. (2006). *Constructing Grounded Theory A Practical Guide Through Qualitative Analysis*. California: Sage Publications Inc. .
- Cochran, B. N., Stewart, A. J., Ginzler, J. A., & Cauce, A. M. (2002). Challenges Faced by Homeless Sexual Minorities: Comparison of Gay, Lesbian, Bisexual, and Transgender Homeless Adolescents With Their Heterosexual Counterparts. *American Journal of Public Health*, 95(5), 773-777.
- Doty, N. D., Willoughby, B. L., Lindahl, K. M., & Malik, N. M. (2010). Sexuality Related Social Support Among Lesbian, Gay, and Bisexual Youth. *Journal of Youth Adolescence*, 1134-1147. doi:0.1007/s10964-010-9566-x
- Ford, M. (2013, May 14). *A Brief History of Homosexuality in America*. Retrieved from Grand Valley State University: <https://www.gvsu.edu/allies/a-brief-history-of-homosexuality-in-america-30.htm>
- Friedman, S., Reynolds, A., Scovill, S., Brassier, F. R., Campbell, R., & Ballou, M. (2013, June). *An Estimate of Housing Discrimination Against Same-Sex Couples*. Retrieved from U.S. Department of Housing and Urban Development: [http://www.huduser.gov/portal/Publications/pdf/Hsg\\_Disc\\_against\\_SameSex\\_Cpls\\_v3.pdf](http://www.huduser.gov/portal/Publications/pdf/Hsg_Disc_against_SameSex_Cpls_v3.pdf)
- Grafsky, E. L., Letcher, A., Slesnick, N., & Serovich, J. M. (2011). Comparison of treatment response among GLB and non-GLB street-living youth. *Children and Youth Services Review*, 569-574.
- Herrick, A. L., Egan, J. E., Coulter, R., Friedman, R., & Stall, R. (2014). Raising Sexual Minority Youths' Health Levels by Incorporating Resiliencies Into Health Promotion Efforts. *American Journal of Public Health*, 104(2), 206-210.
- Keuroghlian, A. S., Shtasel, D., & Bassuk, E. (2014). Out on the Street: A Public

- Health and Policy Agenda for Lesbian, Gay, Bisexual, and Transgender Youth Who Are Homeless. *American Journal of Orthopsychiatry*, 84(1), 66-62.
- McLoughlin, P. J. (2012). Couch surfing on the margins: the reliance on temporary living arrangements as a form of homelessness amongst school-aged home leavers. *Journal of Youth Studies*, 16(4), 521-545.
- Munsey, C. (2006). Emerging adults: The in-between age. *Monitor*, 37(6), 68.
- National Association of Social Workers. (2008). *NASW Code of Ethics*. Washington, DC: NASW Press.
- National Center for Transgender Equality. (2015). *Housing & Homelessness*. Retrieved from National Center for Transgender Equality: <http://www.transequality.org/issues/housing-homelessness>
- Net Industries . (2015). *Homeless Person - Shelter, Economic Assistance, Education, Voting, Antibhomeless Legislation, Further Readings*. Retrieved from <http://law.jrank.org/pages/7397/Homeless-Person.html>
- North Carolina Coalition to End Homelessness. (2014, January 29). *CONTINUUM OF CARE REPORTING FORM: HOMELESS COUNT* (. Retrieved from NCCCH: <http://www.nccch.org/files/4177/>
- Ozbay, F., Johnson, D., Dimoulas, E., Morgan, C., Charney, D., & Southwick, S. (2007). Social Support and Resilience to Stress. *Psychiatry*, 4(5), 35-40.
- Ray, N. (2006). *Lesbian, gay, bisexual and transgender youth: An epidemic*. Retrieved from New York: National Gay and Lesbian Task Force Policy: [http://www.thetaskforce.org/static\\_html/downloads/reports/reports/HomelessYouth\\_ExecutiveSummary.pdf](http://www.thetaskforce.org/static_html/downloads/reports/reports/HomelessYouth_ExecutiveSummary.pdf)
- Rew, L., Whittaker, T. A., Taylor-Seehafer, M. A., & Smith, L. A. (2005). Sexual Health Risks and Protective Resources in Gay, Lesbian, Bisexual, and Heterosexual Homeless Youth. *Journal for Specialists in Pediatric Nursing*, 10(1), 11-19.
- Saewyc, E. M., Skay, C. L., Pettingell, S. L., Reis, E. A., Bearinger, L., Resnick, M., . . . Combs, L. (2006). Hazards of Stigma: The Sexual and Physical Abuse of Gay, Lesbian, and Bisexual Adolescents in the United States and Canada. *Child Welfare League of America*, 195-213.
- Sangha, K. K. (2015, July 16). LGBT Protection in the Workplace—A Survey of State. *Employment Relations Today*, 42(2), 57-68. doi:10.1002/ert
- Shelton, J., & Winkelstein, J. (2014). Librarians and Social Workers: Working Together for Homeless LGBTQ Youth. *Young Adult Library Sources*, 20-24.
- Strauss, A., & Corbin, J. M. (1998). *Basics of Qualitative Research: Techniques and Procedures for Developing Grounded Theory*. SAGE Publications.
- Van Leeuwen, J. M., Boyle, S., Salomonsen-Sautel, S., Garcia, J., Hoffman, A., Hopfer, C. J., & Baker, N. D. (2006). Lesbian, Gay, and Bisexual. *Child Welfare League of America Homeless Youth: An Eight-City Public Health Perspective*, 151-170.
- Walls, E. N., & Bell, S. (2011). Correlates of Engaging in Survival Sex among Homeless Youth and Young Adults. *Journal Of Sex Research*, 48(5), 423-436. doi:10.1080/00224499.2010.501916

# Using a BCI to Assess Attention During an Online Lecture

Ethan Hanner  
Marguerite Doman, Ph.D. (Mentor)

## ABSTRACT

Brain computer interfaces (BCI) use neural signals as input into computer applications. In this study, we demonstrate the use of a low-cost, commercially available BCI to directly measure participants' attention levels while using WUtopia, an online learning platform developed at Winthrop University. Previous research demonstrated that students using this platform performed better on a post-lecture quiz than those who only viewed the lecture (Grossoehme et al.). We hypothesize that the increase in performance is due to an increase in attentiveness when using the WUtopia platform. We divided participants into the intervention ( $n = 7$ ) and non-intervention ( $n = 12$ ) groups. Both groups viewed the chosen lecture video, completed a survey on their experience and attentiveness during the video, and took a quiz on the content of the video while wearing the BCI. Preliminary results corroborate the finding that WUtopia users perform better on post-lecture quizzes. However, readings from the BCI indicate that the non-intervention group had greater attentiveness during the video, while participants in the intervention group rated themselves higher on the attention survey. This suggests that either a) the BCI chosen is not effective at gauging attentiveness or b) there is a disconnect between actual and self-perceived attentiveness.

**KEYWORDS:** Online Education, Attention, Brain-Computer Interface, NeuroSky

## 1. INTRODUCTION

In an increasingly technological world, educators are seeking alternatives to the traditional classroom lecture format that can engage digital natives and, in some cases, reserve valuable classroom time for discussion, experimentation, and questions. Creating online video lectures is just one way to accomplish this. However, simply posting a video lecture online is often not enough; educators must find a way to engage learners in an online setting and ensure understanding and retention of the material.

Researchers at Winthrop University have developed an online learning platform called WUtopia! for delivering video lectures and other instructional material. Alongside lecture in WUtopia!, students are presented with questions linked to specific timestamps in the video and resources such as FAQs and third-party websites. The questions are intended to reinforce important concepts and increase student engagement with the material. In their study, the researchers divided participants into two groups: the intervention group had access

to the questions and resources during the video, while the non-intervention group watched the stand-alone video. After the video lecture, both groups were given a quiz on the lecture's content. The results showed that those in the intervention group not only performed better on the quiz, but completed it in less time than the non-intervention group [1]. In this study, we seek to further these findings by investigating a possible reason for the difference in performance between groups.

## 2. MOTIVATION AND ATTENTION

There has been much research published on the motivation to learn, what influences it, and how it affects learning outcomes. One researcher, Bruinsma, examined the relationship between motivation and academic achievement. Based on the literature and the results of his study, he states that there is a positive correlation between motivation and academic achievement; students who are more motivated tend to perform better than their peers [2]. Thus, when designing instructional content either to be delivered in a traditional classroom

setting or through a multimedia platform, it is important to consider strategies for fostering the motivation to learn. If learners are not motivated, they may be less likely to retain information and more likely to quit or give up when encountering obstacles.

The ARCS Model of Instructional Design by Keller specifies four major conditions for motivation: Attention, Relevance, Confidence, and Satisfaction [3]. The model provides a systematic approach to designing instructional content that motivates learners by meeting these conditions. In particular, attention may be thought of as the precursor to learning – if a student is not paying attention to the material being presented, learning cannot take place. Keller points out that the most difficult aspect of attention is not initially getting the learner’s attention, but rather sustaining that attention over an interval of time. A raised voice, sudden noise, or dramatic line are all effective ways of grabbing attention – but if the information following is dull or unappealing, that attention will quickly be lost.

Existing research attempting to quantify attention in the context of motivation largely relies on participants’ self-reported measures of how attentive they perceived themselves to be during a task. There is a degree of unreliability and uncertainty with this approach, as it is impossible to say whether the participants’ perceptions match reality. A more reliable, objective measure would enable researchers to compare the effectiveness of different approaches to instruction at engaging learners. We are proposing the use of a brain-computer interface (BCI) to measure participants’ brain activity as an indicator of their level of attention while viewing a WUtopia! lecture. We hypothesize that recordings from the BCI will indicate a higher level of attention in the intervention group, which may be a possible explanation for their increased performance on a post-lecture quiz. More generally, we hope to demonstrate the appropriateness of BCI devices as tools to gauge the effectiveness of different pedagogical approaches by utilizing information about the learner’s cognitive state.

### 3. BRAIN COMPUTER INTERFACES AND NEUROSKY

A new frontier is emerging for computing technology: interfacing with the brain. A brain-computer interface (BCI) collects information about a user’s brain activity to be used as input into applications. There are many different methods of obtaining this information, including electroencephalography (EEG) and functional near-infrared spectroscopy (fNIRS), each with their own advantages and disadvantages. Some potential uses of BCI which are already being researched are enabling direct control of a device such as a prosthetic limb or computer interface by motor-impaired users. Other research applications include MindLogger, an application that allows users to build words and sentences by selecting individual letters based on readings from a BCI device, and NeuroPhone, which utilizes the P300 brain signal to select the correct contact to call from a list [4][5]. These are all categorized as “active” BCI. By contrast, “passive” BCI uses information about a user’s brain activity to respond in some way, such as by adjusting elements of an interface or providing feedback to the user. For example, Rebolledo-Mendez et al. developed an artificial intelligence (AI) avatar in the game Second Life that utilized data about a participant’s attention level to give feedback intended to increase or maintain the participant’s attention as they completed a series of multiple choice questions [6]. Some possible responses of the AI included proposing a different activity if the attention level was low or suggesting supporting resources and material to further engage the participant with the subject matter. Verkijika et al. also showed that a BCI can be used to assess students’ levels of math anxiety and track changes over time [7].

As an alternative to medical-grade EEG devices that can be prohibitively expensive, the company NeuroSky has developed a low-cost, commercially available EEG device consisting of one dry electrode placed directly onto the user’s forehead. This device, the NeuroSky

MindWave Mobile, reads the electrical signals generated by the brain as it performs tasks. Using a proprietary algorithm, the MindWave processes these signals and reports the user’s attention level at a frequency of 1 Hz. Attention is output as a number in the range of 0 to 100; the meaning of each possible value is shown in Table 1. Previous research has demonstrated the ability of NeuroSky’s EEG devices to accurately detect a user’s mental state and use it as input into novel applications [8][4][6].

#### 4. METHODS

For this study, a TED talk on microbial communities by Rob Knight was chosen as the lecture video. The lecture was between seventeen and eighteen minutes in length. The researchers devised questions from the content for the quiz and to display alongside the video.

Participants in the study were randomly assigned to either the intervention or non-intervention group. While watching the lecture video, the intervention group was presented with a series of questions linked to particular timestamps in the video. The questions would automatically update as the video progressed.

**Table 1.** The meanings of each of the possible ranges of attention values output by the MindWave Mobile according to the documentation on NeuroSky’s website

Value	Meaning
0	Special value indicating that the attention level cannot be calculated with a reasonable amount of reliability, usually due to excessive noise
1 – 20	Attention is “strongly lowered”
20 – 40	Attention is “reduced”
40 – 60	Attention is “neutral” – baseline
60 – 80	Attention is “slightly

	elevated”
80 – 100	Attention is “elevated”

These questions were intended to reinforce the material and increase engagement with the lecture content. The control group viewed the same video but without any supplemental questions.

After watching the video, both groups were asked to complete a survey asking them to provide demographic information and reflect on their experience during the lecture. Participants were asked whether they paused, rewound, or fast forwarded the video and whether they took notes on the content. For the intervention group, a question on the survey asked them to rate how beneficial they felt the questions were in aiding them with learning the material in the video. The bulk of the survey was a self-reported measure of attention and mind wandering. The survey asked participants to report the frequency of their mind wandering during the video, rate their level of attention on a scale of 1 (low) to 7 (high), and report the degree to which they felt their behavior during the study matched selected criteria for ADHD from the DSM-V. The latter portion of the survey was adapted from Rebolledo-Mendez et al. [6]. Responses from the survey were compared against actual attention levels recorded by the MindWave to determine the effectiveness of the device, and responses were also compared between groups as another measure of the difference in attention for the two groups.

After completing the survey, both groups were given a quiz on the material presented in the lecture. The quiz questions were identical for both groups to avoid differences in performance based on subject matter or question style. The quiz was worth fourteen points; one point for each correct answer, and an additional point each for answering the two questions with multiple answers correctly with no incorrect answers chosen. Participants were given a final score out of 100%.

Because the MindWave reports an attention value once per second, we elected to examine the average value reported in fifteen-second samples once every two minutes. Based on a previous study on video production and student engagement, a video lecture should ideally be presented in chunks of six minutes or less [10]. Therefore, we chose to examine attention during the first eight minutes and fifteen seconds of watching the video; the extra two minutes was intended to determine how attention changed after the six minute mark, and the fifteen seconds was needed to get a full sample at eight minutes. This led to the creation of exclusion criteria – in order to be considered in the final sample, the participant must have watched the video for at least eight minutes and fifteen seconds. Additionally, participants must have completed the survey and quiz (blank answers were permitted) and must have answered I agree to the prompt on the survey “Do you agree to be as honest as possible and accurate to the best of your ability while participating in this survey?”

## 5. RESULTS

### 5.1 Demographics

A total of 19 participants completed the survey and met the criteria for inclusion. They were divided into the intervention (n = 7) and non-intervention (n = 12) groups. The sample was comprised primarily of college students at Winthrop University – approximately 74% (n = 14) reported their education level as “some college.” Participants were approximately 74% female (n = 14) and 26% male (n = 5).

### 5.2 MindWave Recordings

We found the opposite effect of what was expected in recordings from the BCI. For each of the 15 second intervals, the average attention rating was higher for the non-intervention group than for the intervention group. Further, the overall average attention rating (taken from 0:00 to 8:14) for the non-intervention group was 52.75 versus 47.93 for the non-intervention group. For both groups, the average attention rating at each interval and overall remained within the baseline range – 40 to 60 – although some individuals peaked as

high as 73.6 and dipped as low as 20.81. The averages for both groups are given in Table 2.

**Table 2.** Average attention rating from both groups at each sample interval.

Sample	Intervention Group	Non-Intervention Group
Sample 1 (0:00 – 0:14)	53.1	57.99
Sample 2 (2:00 – 2:14)	47.15	52.86
Sample 3 (4:00 – 4:14)	46.52	50.76
Sample 4 (6:00 – 6:14)	41.64	45.84
Sample 5 (8:00 – 8:14)	42.98	53.01
Overall (0:00 – 8:14)	47.93	52.75

As seen in Table 2, the average attention value for both groups tended to decrease at each successive interval, although for the final sample it increased for both. This increase was more pronounced for the non-intervention group.

### 5.3 Frequency of Mind Wandering and ADHD Criteria

Both groups were asked during the survey to report approximately how many times their mind wandered during the video lecture. The choices were 0 – 1 times, 2 – 3 times, 4 – 5 times, or 5+ times. For both groups, the most frequent response was 2 – 3 times – with approximately 57% (n = 4) for the intervention group and approximately 42% (n = 5) for the non-intervention group. Only about 14% (n = 1) in the intervention group reported 4 -5 times, while about 33% (n = 4) reported 4 – 5 times in the non-intervention group.

Each participant was asked to rate their attention on a scale of 1 (low) to 7 (high) and

also the frequency with which they experienced selected criteria for ADHD from the DSM-V during the lecture, from 1 (all the time) to 7 (never). Some of these criteria included “Difficulty staying in one position,” “Difficulty following through on instructions,” and “Difficulty listening to what is being said by others.” The responses to each of these prompts were averaged for each participant to arrive at a self-perceived attention rating. For these ratings, we found the opposite of what was indicated by the MindWave recordings; the intervention group rated themselves at 5.88 on average (sd = 0.70) while the non-intervention group rated themselves at 5.64 on average (sd = 1.36).

#### 5.4 Quiz Performance

As in the previous WUtopia! study, participants in the intervention group performed better on the post-lecture quiz than those in the non-intervention group. The average score for the intervention group was 76.53% (sd = 6.29%). For the non-intervention group, that average was 73.22% (sd = 12.75%). For the three questions that were repeated from alongside the video, 100% of the intervention group answered correctly on the quiz. The non-intervention group, which did not see these questions alongside the video, did not answer all three correctly.

## 6. DISCUSSION

It is important to note that these results are preliminary, as after applying the exclusion criteria we did not meet the minimum number of participants required to perform a full statistical analysis. Of particular interest at this point, however, is that the MindWave recordings, where the non-intervention group fared better, seem to be in conflict with the self-reported attention rating, where the intervention group scored higher. The two scores were not clearly correlated in individual participants, either; in the intervention group, the participant with the highest overall attention rating from the MindWave (60.61) had the lowest self-reported attention rating (4.5) and in the non-intervention group, the participant with the highest self-reported attention rating (6.88) had the third lowest overall attention rating from the

MindWave. This suggests that either a) the BCI chosen is not effective at gauging attentiveness or b) there is a disconnect between actual and self-perceived attentiveness. More data is needed to reach a conclusion on this matter.

The preliminary results indicate a limit on the length of video that can be effectively used in the WUtopia! setting. It appears that for the intervention group, the presence of questions alongside the video and the ability to move forward in the video led to participants quickly scrolling through the questions without watching the full video. Indeed, the average time spend watching the video for the intervention group was 15 minutes and 52 seconds, versus 19 minutes and 57 seconds for the non-intervention group. This effect was not observed in the previous WUtopia! study, where the lecture video was much shorter.

While this study corroborates the finding that the use of the full WUtopia! platform leads to better performance on the post-lecture quiz, the difference in scores were not as pronounced as in the previous study. The researcher who devised the questions notes that this may be due to the choice of relatively easy questions that were pulled directly from the video, rather than questions which required full understanding and application of the material presented.

## REFERENCES

- [1] Grossoehme, N., Doman, M., and Moore, A. Effectiveness of Coordinating Artifacts in an Online Tutoring System. Unpublished manuscript.
- [2] Bruinsma, M. Motivation, cognitive processing and achievement in higher education. *Learning and Instruction*, 14 (2004), 549-568.
- [3] Keller, J. M. Development and Use of the ARCS Model of Instructional Design. *Journal of Instructional Development*, 10 (3), 2-10.
- [4] Najeeb, D., Grass, A., Garcia, G., Debbiny, R., and Nahapetian, A. MindLogger: A Brain-Computer Interface for Word Building using Brainwaves. in *1st Workshop on Mobile*



- Medical Applications*, (Memphis, USA, 2014), ACM Press, 6-11.
- [5] Campbell, A.T., Choudhury, T., Hu, S., Lu, H., Mukerjee, M.K., Rabbi, M., and Raizada, R.D.S. NeuroPhone: Brain-Mobile Phone Interface using a Wireless EEG Headset. In *ACM SIGCOMM 2010*, (New Delhi, India, 2010), ACM Press, 3-8.
- [6] Rebolledo-Mendez, G., Dunwell, I., Martinez-Miron, E. A., Vargas-Cerdan, M. D., de Freitas, S., Liarokapis, F., and Garcia-Gaono, A. R. Assessing NeuroSky's Usability to Detect Attention Levels in an Assessment Exercise. in *Human-Computer Interaction, New Trends*, (San Diego, USA, 2009), Springer Berlin Heidelberg, 149-158.
- [7] Verkijika, S. F. and De Wet, L. Using a brain-computer interface (BCI) in reducing math anxiety: Evidence from South Africa. *Computers & Education*, 81, 113-122.
- [8] Crowley, K., Sliney, A., Pitt, I., and Murphy, D. Evaluating a Brain-Computer Interface to Categorise Human Emotional Response. in *IEEE 10<sup>th</sup> International Conference on Advanced Learning Technologies*, (Sousse, Tunisia, 2010), IEEE, 276-278.
- [9] Guo, P. J., Kim, J., and Rubin, R., How Video Production Affects Student Engagement: An Empirical Study of MOOC Videos. in *Learning @ scale '14*, (Atlanta, USA, 2014), ACM, 41-50.

# Comparing the tensile and compressive Young's moduli of cortical bone

Deshawn Hoskins  
Meir Barak, Ph.D., D.V.M. (Mentor)

## ABSTRACT

Various methods have been used in the testing of the mechanical properties of cortical bone, specifically the young's modulus. However, in the case of the material's Young's modulus in compression and tension, there is a significant disagreement among the published findings that may be a result of experimental artifacts. This study attempts to solve the scientific question of whether cortical bone is stiffer in compression or tension and if so to understand why that is. Using small samples taken from the distal portion of the neck of a femur belonging to a young white tailed deer, both the Young's moduli in tension and compression were calculated for each sample. The sample was placed under loads that wouldn't result in plastic deformation [max load of 140 Newtons) thus allowing the ability to use the same sample for both tension and compression without compromising its mechanical properties. Results show that elastic modulus is greatest while in tension, specifically in the load bearing cranial orientation.

## INTRODUCTION

Due to the lack of standardization or consistent testing methods, previous studies on cortical bone have no defined conclusion as to whether it is stronger in tension or compression. Some sources state that cortical bone in compression is stronger, some suggest that tension is greater, while others state that there is no significant difference at all. It is difficult to gain validation or compare the works of various authors because each experiment was carried out using different methodical procedures. With so many uncontrolled parameters in play, this makes it practically impossible to compare at eyes view. In addition to this, calculations of the Young's modulus in cortical bone can vary across species, across different bones within that species and even across different regions of the same bone. Different samples have the potential to have completely different mechanical properties. This is why the data collected from samples measured in tension can not be easily compared to those measured in compression, even if the same methods and procedures were performed. Our study attempts to neutralize or minimize these possible errors, resulting in a more controlled experiment by using the same sample tested in both tension and compression. Taking

this approach guarantees that the material composition is exactly the same for each individual test subject measured in tension and compression.

### *Bone Composition*

Bone is made up of a combination of organic and inorganic elements. The mineral component is composed of insoluble salt crystals called hydroxyapatite. Hydroxyapatite, which makes up roughly 60% of the bone, contains large volumes of calcium and phosphate minerals along with traces of other minerals such as magnesium, sodium, and bicarbonate. This, together with organic collagen fibers, gives bone its strength and rigidity. The remaining 20% is composed of water, like all living tissues, and provides some flexibility to the rigid backbone.

### *Mechanical Properties*

Thanks to this unique composition, bone exhibits viscoelastic behavior, meaning that unlike completely stiff and elastic materials, bone dissipates energy in the form of heat as it is loaded in an attempt to regain equilibrium. Thus the strain rate is dependent upon time, allowing the bone to gradually return to its original shape after a load has been applied. In addition to this viscoelasticity several other properties affects the bone's mechanical

properties. Every bone is unique with the ability to change its composition based on its environmental feedback. In accordance with renowned German anatomist Julius Wolff, Wolff's Law states that bone will adjust its structure to better accommodate mechanical loads placed upon it. Bones that are under high stress may contain more inorganic minerals while those that are under lower levels of stress may have a composition that contains more collagen and water. Living bone (In vitro) is constantly changing and works in an endless feedback loop to continuously optimize its mechanical behavior. Mineral content contributes a lot to a bone's strength, but can also be affected by a number of factors including the amount of water and the presence or absence of bone diseases such as osteoporosis which degenerates and changes the architecture of the bone.

#### *Application*

Conclusive evidence of this scientific question has substantial use in applications such as bone grafting and prosthetics. Bone disease such as osteoporosis is a growing epidemic worldwide. An estimated 1.5 million individuals suffer a fracture due to bone disease each year. With a constantly aging population, this will be a problem for years to come. Roughly 50 million individuals over age 50 have bone degeneration of the hip and are at risk of complications later in life. It is projected that by 2020, one in two Americans over age 50 will have or be at risk of suffering from some sort of bone disease. Medical advancements such as hip implants and bone grafts have allowed individuals with bone disease to have a better quality of life. These materials that are put in the place of bone attempts to replicate its function; however they can not do so without properly knowing the properties of the bone itself. This is imperative especially for implants because they can't change its mechanical properties like bone can. It also affects the surrounding tissues and could potentially result in even more serious problems if the implant fractures or if it is too stiff. This would cause the bone to resorb due to stress shielding and thus further accelerate osteoporosis.

#### *Young's Modulus*

Young's modulus, also known as elastic modulus, is used to measure the ability of a solid material to endure changes in length while under lengthwise tension or compression. This helps to provide a numerical value to describe a material's mechanical properties. It is expressed by the following equation: Young's Modulus =  $(FL_0)/A(L_n - L_0)$  and defines the relationship between stress (force per unit area) and strain (proportional deformation). A force  $F$  in the form of tension or compression is applied to a specimen at each end with a cross-sectional area  $A$ . This causes the specimen to change its original length  $L_0$  to some new length  $L_n$ . The stress is defined as the quotient of the tensile force divided by the cross-sectional area, or  $F/A$  and the strain or relative deformation is the change in length,  $L_n - L_0$ , divided by the original length, or  $(L_n - L_0)/L_0$ . A solid body deforms when excessive loads are applied to it. The material displays elastic behavior if the body returns to its original shape after the load is removed, thus signifying that no deformation has occurred. Bone is known to start displaying plastic deformation under loads exceeding 150N. For experimental purposes, the specimen will undergo max loads of 140N in order to avoid plastic deformation, allowing the ability to reuse the specimen without compromising its mechanical properties.

#### **MATERIALS AND METHODS**

The right femoral bone was harvested from a white tailed deer that died to causes unrelated to failure of the musculoskeletal system. Using a handsaw, a 40 mm portion of its diaphysis was taken from the distal portion of this bone and the interior bone marrow was removed. Following this the small shaft was divided into four equivalent regions, each belonging to each orientation of the bone; Cranial (Front), Caudal (Rear), Medial (Side closest to the body) and Lateral (Side farthest from the body). Doing so helps to see if there is any difference in the mechanical properties of the bone based on the loading direction, which is basically checking for proof of Wolff's Law. Wolff's Law states that that bone grows and remodels in response to the forces that are

placed upon it. Specific directions experience different stresses that the body picks up and remodels the bone to become most efficient at supporting the load. From each region four 2x2x40mm samples were cut using a Allied TechCut4 Bone saw with a 4x.012x.05in diamond metal wafering blade. To do so, the bone had to be binded to the saw using an inorganic Jet acrylic that was made in the lab from a liquid powder resin mix.

To better simulate wet bone, each sample was allowed to soak in water 24hrs prior to testing. Individually the samples were taken and loaded in tension on an Instron 5942 machine with only 4mm of the sample exposed, which was the test site. A load of 0-140N was placed on the sample at a strain rate of .5. These values apply loads that are similar to real-life expectations and at a desirable rate to ensure that the bone won't fracture. This all occurs within the elastic region of bone, meaning that under these parameters no deformation of the bone will occur. From this test, the Young's

Modulus was gathered and stored. The sample was unloaded, reloaded and tested a second time to confirm the accuracy of our data where similar results minimized the chance of slippage.

Immediately following this, the sample was cut into a 2x2x4mm beam, the same exposed region that was tested in tension. The Instron machine is restructured to test in compression and the now smaller beam is loaded. To keep the beam stabilized, a pea size amount of Filtek Z250 resin based Dental Restorative Material was added to the load sites (top and bottom of the beam). This composite was polymerized, exposing it to UV light. Each load site was treated for 30 sec. Using the same parameters, 140N max load, .5 strain rate, the Instron machine can now test the same sample in compression. This setup can be seen in figure 1. Once again the Young's Modulus was calculated twice, once for each time the procedure was ran. After all of the samples were measured in both tension and compression, the results could be compared.

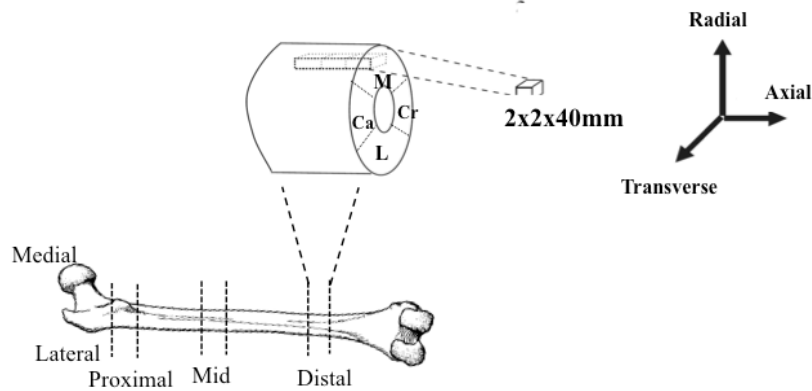

**Figure 1:** Figure showing the 40 mm section of the femur the test samples were retrieved from as well as how the caudal, cranial, medial and lateral quadrants were established.

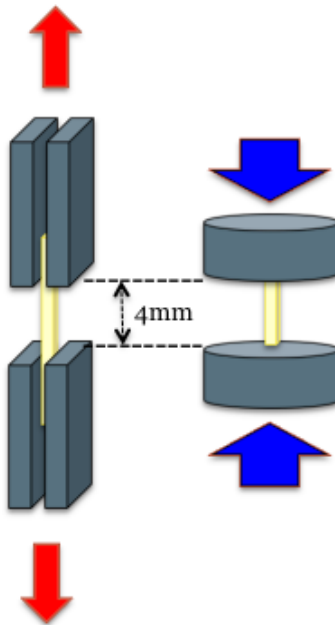

**Figure 2:** Diagram showing the setup of the Instron machine. The specimen was first placed inside the instron which pulled the sample, applying tensile forces. As the material is being pulled, its elongation could be automatically observed and documented by the Instron machine. Over time this will output a resulting curve or tensile profile showing how the materials react to the forces being applied. The sample was cut and repeated in compression.

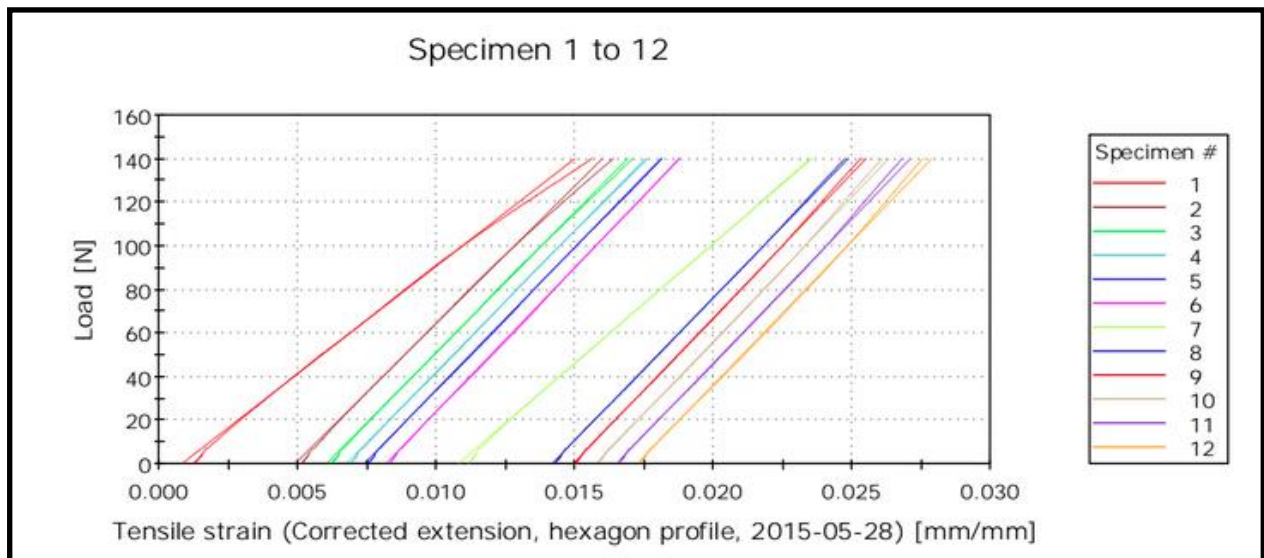

**Figure 3:** Original data showing the continuous elastic behavior of the specimen tension under cyclic loading.

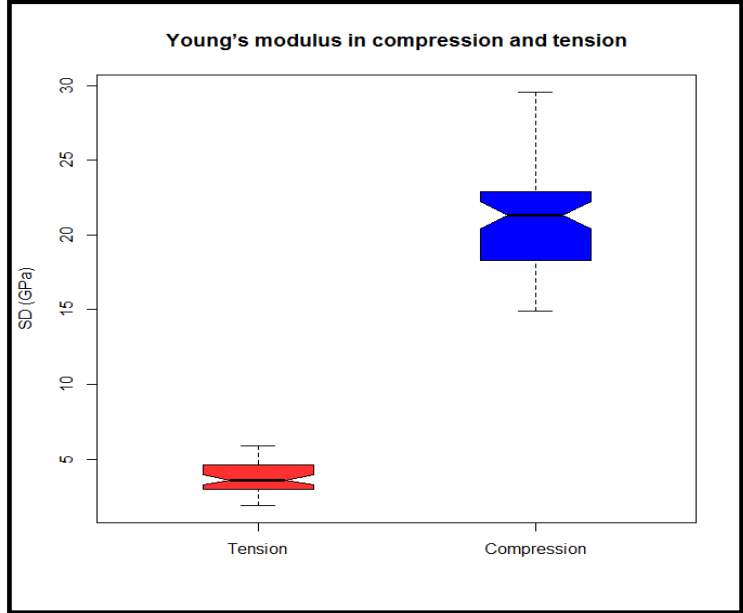

**Figure 4:** The box and whisker plot shows that the stiffness of bone in Compression is significantly greater than that in tension.

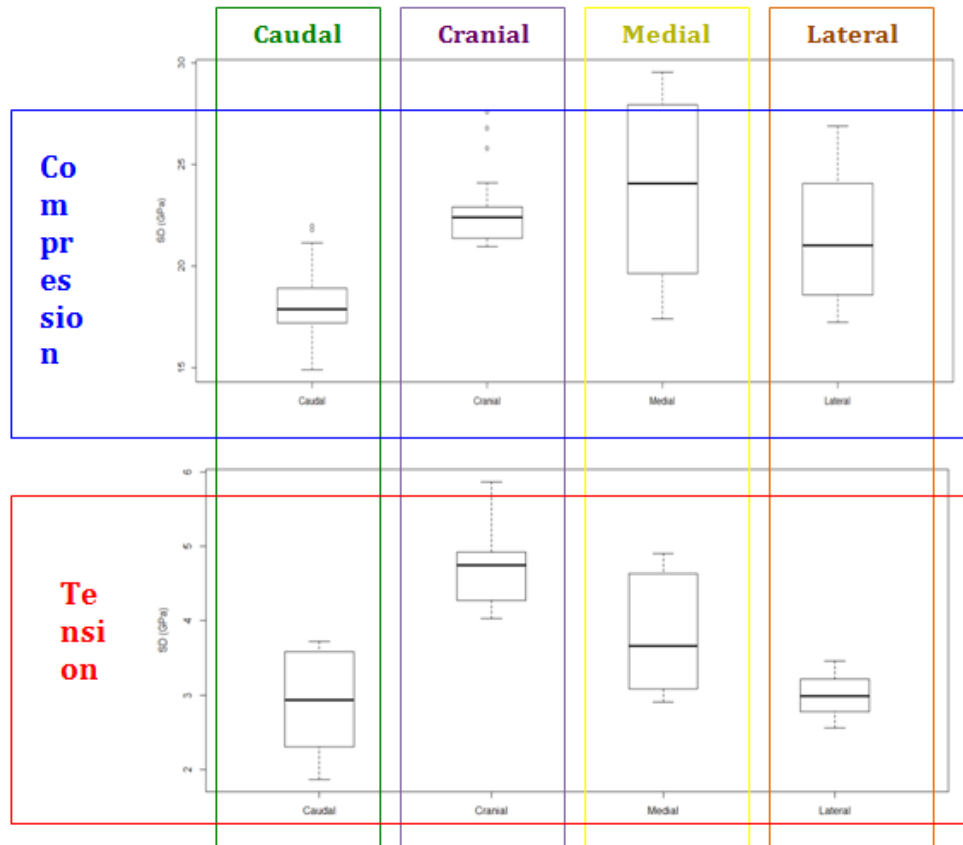

**Figure 5:** Diagram comparing the Young's modulus of cortical bone in tension and compression by region (Caudal, Cranial, Medial and Lateral).

## DISCUSSION AND CONCLUSION

As seen in figure 4, the Young's modulus of cortical bone was significantly higher in compression than in tension. Comparing the quadrants, shown in figure 5, the stiffness of cortical bone in compression for the caudal region is much lower than the other three orientations, which are relatively similar. However, when compared in tension, the cranial region was the stiffest while the others were similar. Extrapolating the data, the cranial region showed the highest stiffness, followed by the medial and lateral region (tie) and lastly the caudal region. While cortical bone influenced heavily whether it is in tension or compression, the orientation that the bone comes from has a significant affect as well, specifically the cranial and caudal regions. These findings would have to be repeated for accuracy, as there are a number of factors that could have influenced the results. This includes but is not limited to,

not having enough samples to establish a normally distributed curve, the inability to measure compression before tension, or having inadequate hydration of the samples before loading. As stated previously, viscoelastic materials release energy as heat, so when force was applied in tension, it may have dehydrated the sample, making it more stiff and brittle. The samples were cut and tested after only 30 minutes of rehydration (submerged in water), which may not have been long enough. While further studies would have to be done, the data suggest that the elastic modulus is greatest while in tension, specifically in the load bearing cranial orientation.

## REFERENCES

1. Clarke, B. (2008). Normal bone anatomy and physiology. *Clinical journal of the American Society of Nephrology*, 3(Supplement 3), S131-S139.

2. Turner, C. H., Rho, J., Takano, Y., Tsui, T. Y., & Pharr, G. M. (1999). The elastic properties of trabecular and cortical bone tissues are similar: results from two microscopic measurement techniques. *Journal of biomechanics*, 32(4), 437-441.
3. Sedlin, E. D., & Hirsch, C. (1966). Factors affecting the determination of the physical properties of femoral cortical bone. *Acta Orthopaedica*, 37(1), 29-48.
4. Bayraktar, H. H., Morgan, E. F., Niebur, G. L., Morris, G. E., Wong, E. K., & Keaveny, T. M. (2004). Comparison of the elastic and yield properties of human femoral trabecular and cortical bone tissue. *Journal of biomechanics*, 37(1), 27-35.
5. Gray, H. (1918). *Anatomy of the human body*. Lea & Febiger.
6. Crowninshield, R. D., & Pope, M. H. (1974). The response of compact bone in tension at various strain rates. *Annals of Biomedical Engineering*, 2(2), 217-225.
7. Røhl, L., Larsen, E., Linde, F., Odgaard, A., & Jørgensen, J. (1991). Tensile and compressive properties of cancellous bone. *Journal of biomechanics*, 24(12), 1143-1149.
8. Alberts, B. et al. (1994). *Molecular biology of the cell*. Garland Press, 3rd ed.



# Determination of phylo-group diversity of *Escherichia coli* in environmental sand samples collected from a South Carolina beach

Savannah Moritzky  
Victoria Frost, Ph.D. (Mentor)  
Matthew Heard, Ph.D. (Mentor)

## ABSTRACT

*Escherichia coli* (*E. coli*) is a common bacterial species that can persist in many environments found around the world. One environment where it can be found that is of particular concern is an oceanic beach, where it can serve as an indicator of both fecal and microbial pollution. While the majority of strains of *E. coli* are non-pathogenic to humans, some phylo-groups are associated with virulent strains and could cause disease. Therefore, it is of critical concern that we determine where this *E. coli* is coming from and whether it is potentially harmful to human health and well-being. In this study, we attempted to answer this question by using a newly developed molecular technique, which allows us to identify which phylo-groups environmental isolates of *E. coli* belong to. Classification into phylo-groups can help infer the source of the pollution. For this analysis, we collected sand samples from Folly Beach, SC, which is one of the most visited beaches in the Southeastern US. In our analysis, we identified environmental isolates of *E. coli* that differ from the lab strain and belong to two distinct phylo-groups including phylo-group A, which is likely from human fecal contamination and phylo-group B1, which is likely from a domesticated and/or wild animal source. The same molecular technique was altered to test for virulence factors of *E. coli*, and all isolates showed a band corresponding to a virulence factor, but further analysis is needed to determine the validity of this technique. Collectively, our findings indicate that multiple types of *E. coli* are able to persist in these environments and that more research is needed to determine whether these strains are of public health concern.

## INTRODUCTION

*Escherichia coli* (*E. coli*) is a rod-shaped, gram negative bacterium that is very common in the intestines of animals such as humans and birds. The prevalence of *E. coli* make them a common subject for studies such as genetic tests, and much is known about the genome of *E. coli*. Most strains are non-pathogenic, but some pathogenic strains can cause illnesses if ingested. *E. coli* have also been shown to survive outside of their host in many different ecosystems (Halliday et al 2012). Because *E. coli* can be found in so many different environments, they show a vast genetic diversity that can be used to classify them into different groups, which can later be used to determine the original source of the bacteria.

*E. coli* are also important because they are classified as Fecal Indicator Bacteria (FIB) species, which means that when they are present in an ecosystem, they may indicate signs of

pollution or the presence of other pathogens. This distinction is important because it means that agencies such as the EPA who assess pollution levels can do one test for *E. coli* in a sample and can assume that if *E. coli* are present that other unwanted pathogens may be there as well. Since FIBs have been found to persist in beach sand, it makes the testing of beach sand samples a relevant way to determine whether other unwanted bacteria could be present in places with a large amount of human contact.

*E. coli* are generally unable to persist in oceanic beach sand and must come from an outside source. Therefore, once the presence of *E. coli* is detected, questions arise about its origin. One way to determine the origin of the bacteria is through a method called multi-plex PCR. Clermont et al. created a type of multi-plex PCR that places *E. coli* into separate phylo-groups, which can be analyzed to determine the potential origin of the *E. coli* (2013). Knowledge

of the origin of the *E. coli* contamination is important for a variety of reasons including preventing it from occurring again. For example, many seagulls in Portugal have been found to harbor multi-drug resistant *E. coli* and are a target of public health concern (Simoes et al 2010). By determining their most likely causes, the people and animals of the beach can be better protected, and the amount present can hopefully be reduced.

Another important consideration is whether or not the *E. coli* that are present in oceanic beach sand are virulent and can cause clinical disease in humans. Each phylo-group also has distinct characteristics including the presence of virulence factors and so determining which phylo-group they originate from can indicate how concerning these pathogens are. For example, in phylo-group B2 and D, strains have been determined to be more likely to cause “extra-intestinal infection” than those in group A or B1 (Clermont et al 2013). Phylo-groups B2 and D have also been determined to have more virulence factors than the others (Johnson and Stell 2000). By analyzing certain virulence factors such as the Shigella-like toxins and attachment proteins, the pathogenicity of the strains of *E. coli* found on the beach can be analyzed and precautions can be taken to prevent these pathogens from growing more abundant on the beach sand.

In this study, we collected samples of beach sand from Folly Beach, South Carolina, to determine the origins of *E. coli* and whether or not the samples are showed signs of virulence. To do this, we used the Clermont method of multi-plex PCR to place the *E. coli* samples into phylo-groups and to determine what animals they could have potentially originated from. The same DNA samples were also used to determine whether or not virulence factors were present. Collectively, this approach allows us to determine the origin of *E. coli* in this ecosystem and whether it is of substantial public health concern.

## MATERIALS AND METHODS

We collected sand samples from Folly Beach, South Carolina using sterile conical flasks on three sections of the beach: the dunes,

the intertidal zone, and the subtidal zone. All of these samples were put onto coli plates to determine that *E. coli* was present. The plates that showed the most fluorescence were recorded, and those samples were grown on Levine eosin methylene blue (EMB) agar plates (Neogen 2011).

From the original sand samples, a total of 7.0 grams of sand were added to 35 mL of water in a sterile conical flask. The flask was shaken for 2 minutes and allowed to settle for 30 seconds before 50.0  $\mu$ L of water from the flask was pipetted onto an EMB plate and incubated at 37°C. The plates were examined after 24 and 48 hours and single, metallic *E. coli* colonies were re-isolated onto fresh EMB plates until only metallic colonies were growing on the plates. The isolated metallic colonies from each sample were re-inoculated into a broth at 37 °C.

The broth was diluted to the McFarland Standard ( $1.5 \times 10^8$  CFU/mL) and the DNA was extracted using the Qigen miniprep kit. We performed multi-plex PCR using different primers for each test, and each PCR gel was compared to a 100 bp ladder. The environmental strain’s DNA was also compared to a lab strain of *E. coli*, K-12, which is isolated from the human gut. The DNA used in both the phylo-grouping and virulence factor reactions were the same environmental strains isolated.

### *Phylo-grouping*

The sets of primers for the multi-plex PCR are the following: *ChuA1b*, *ChuA2*, *yjaA1b*, *yjaA2b*, TspE4C2.1b, TspE4C2.2b, *Acexf*, and *ArpA1r*. Each primer was used in the amount of 20 pmol (Clermont et al 2013). 1.0  $\mu$ L of all of the primers except *Acexf* and *ArpA1r* were added to 10  $\mu$ L of DNA and 5.0  $\mu$ L of deionized water. For *Acexf* and *ArpA1r* 2.0  $\mu$ L was added to the 10  $\mu$ L of DNA and other primers along with 5 $\mu$ L of deionized water.

A T100 Thermal Cycler was used for the following cycles:

Temperature (°C)	Cycle Time	Number of Cycles Repeated
94	4 minutes	N/A
94	5 seconds	30 cycles
59	20 seconds	
72	5 minutes	
4	∞	N/A

**Table 1:** The cycles used for the phylo-group PCR method.

A 2.0% agarose gel was run at 60 volts for 90 minutes. The bands were compared to Clermont et al. to determine in which clades the *E. coli* strains belong (2013).

#### Virulence factors

Using the same DNA samples, a virulence factor multi-plex PCR was also performed using the genes *stx1*, *stx2* and *eaec*. Each primer was diluted to 2.0 μM (SOURCE).

1.0 μL of all of the primers were added to 10 μL of DNA and 4.0 μL of deionized water.

A T100 Thermal Cycler was used for the following cycles:

Temperature (°C)	Cycle Time	Number of Cycles Repeated
95	5 min	N/A
95	30 sec	35 cycles
60	30 sec	
72	90 sec	
72	5 min	N/A
4	∞	N/A

**Table 2:** The cycles used for the virulence factor PCR method.

A 1.5% agarose gel was run at 90 volts for 185 minutes. The bands were then

compared to the results of Yang et al 2014 to determine if any virulence factors were present.

## RESULTS

In the sample collection, we found large amounts of *E. coli* and were able to isolate the following samples:

Sample Lane	Isolated Region	Time Isolated
1	Human intestines (lab strain, K12)	N/A
2	Dunes	June 2014
3	Dunes	June 2014
4	Dunes	March 2015
5	Intertidal zone	April 2015

**Table 3:** The sample lanes and the time and location where each sample was found. The same samples were used for both experiments, so this table can be referenced to determine the location of the environmental strain for both gels shown (figure 1 and 2).

The multi-plex PCR reaction for the phylo-groups was compared to Clermont et al to determine to which phylo-group each sample corresponds (2013) (see figure 1). The virulence factor PCR was compared to Yang et al to determine whether or not the virulence factors tested for were present in the sample DNA.

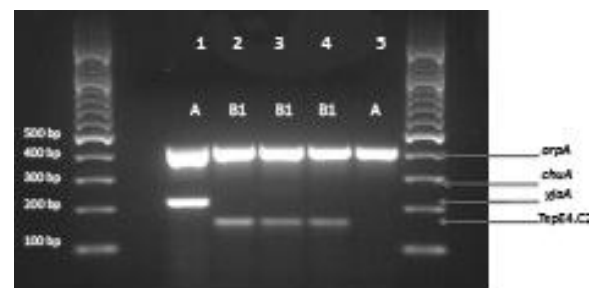

**Figure 1:** The phylo-group PCR results run on a 2.0% gel. The lane numbers are referenced in table 2. Lane 1 contains bands that are around 350 and 220 bp; lanes 2, 3, and 4 all contain bands that are

approximately 350 bp and 180 bp; lane 5 contains a band that is approximately 350 bp. The gene that each band size corresponds to is also shown on the right.

The K12 in the first lane (figure 1) has been sorted into phylo-group A. Phylo-group A has been known to be associated with humans, so K12, which is associated with the human gut should be sorted there (Carlos et al 2010). This acts as a sort of positive control for the experiment. The DNA found in lane 5 that came from the intertidal zone in April (figure 1) was also found to belong to phylo-group A. The DNA in lanes 2-4 (figure 1) has been sorted into phylo-group B1, which is most closely associated with wild and domestic animals (Carlos et al 2010).

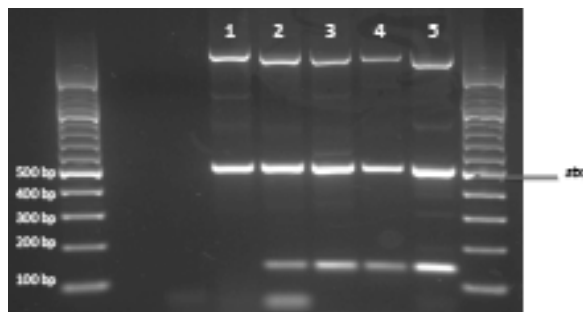

**Figure 2:** The virulence factor PCR results run on a 1.5% gel. The lane numbers are referenced in table 2. There are bands in lanes 1-4 that are over 2000 bp and a band that is approximately 500 bp. Lanes 2-4 also have a band that is approximately 150 bp, and lane 2 has one that is around 50 bp.

The multi-plex PCR analysis demonstrated that there was a presence of a virulence factor around 500 bp in all of the samples (figure 2). This virulence factor is the gene *stx<sub>2</sub>*, which may correspond to the *stx<sub>2</sub>* gene.

## DISCUSSION

In our study, we found *E. coli* from two different phylo-groups (A, B1) in the sand at Folly Beach, SC (Fig. 1). These findings are of concern because samples from phylo-group A could indicate potential signs of human fecal pollution and those from phylo-group B1 are most closely associated with the fecal waste of

wild and domestic animals (Carlos et al 2010). Since seagulls have been a known source of *E. coli* on oceanic beaches, this is most likely the source of this contamination of the dunes (Simoes et al 2010).

We also found virulence factors in all samples (Fig. 2). This virulence factor identified in our study results from expression of the gene *stx<sub>2</sub>*, which is a Shiga-like toxin (Yang et al 2014). However, whether or not if the *stx<sub>2</sub>* gene is present in the *E. coli*, there should be little concern by the public about this finding. The *stx<sub>2</sub>* gene codes for a Shiga-like toxin that can cause bloody diarrhea and other unwanted symptoms, but without the *eae* gene co-occurring, it is unlikely to cause any harm to the host. This is because the *stx<sub>2</sub>* gene is the toxin, but the *eae* gene is the one that codes for the protein that allows it to stick to the membrane before the toxin is released to the cell (Yang et al 2014). Interestingly, the *stx<sub>2</sub>* gene was found in the K12 laboratory strain isolated. Generally, the K12 strain does not possess this gene; so further analysis must be done to conclude why this band is being expressed.

An important limitation of this study was that we had a small number samples of *E. coli* with which we could work and that we only collected samples from one beach. Therefore, in future research, we would collect more sand samples from a variety of beaches to use to isolate different strains of *E. coli*. In addition, we would also like to look for signs of antibiotic resistance that may be emerging in these environments. Previous research has shown that phylo-groups B1 and D have been found to harbor many extended-spectrum  $\beta$ -lactamase producing (ESBL) *E. coli* in seagulls (Simoes et al 2010). Here, we found bacteria in phylo-group B1, so further testing of this DNA for signs of antibiotic resistance would be important.

## CONCLUSION

From the samples we collected, there were isolates from two different phylo-groups present. Phylo-group A, which usually pertains to humans, and phylo-group B1, which is usually associated with wild and domesticated animals. Along with this, a virulence factor that

codes for the Shiga-like toxin gene, *stx<sub>2</sub>*, was found in all of the samples including the K12 strain. The presence of fecal indicator bacteria in beach sand that originates from humans could be a cause for concern that could be linked to some sort of pollution of our beaches by an outside source such as a sewage overflow. The virulence factors found should not be of concern to the public because there were bands that were not co-occurring with those from the *eae* gene, which is necessary to make them pathogenic. Further research is needed to better understand where these bacteria are coming from, and whether or not they pose an imminent threat to beach goers.

community by monitoring sanitary sewage. *App and Environ Micro.* 80(1): 1633-1638.

### LITERATURE CITED

- Carlos C, Pires MM, Stoppe NC, Hachich EM, Sato MIZ, Gomes TAT, Amaral LA, Ottoboni LMM. 2010. *Escherichia coli* phylogenetic group determination and its application in the identification of the major animal source of fecal contamination. *BMC Micro.* 10(161): 1-10.
- Clermont O, Christenson JK, Denamur E, Gordon DM. 2013. The Clermont *Escherichia coli* phylo-typing method revisited: improvement of specificity and detection of new phylo-groups. *Environ Micro Rep.* 5(1):58-65.
- Halliday E, McLellan SL, Amaral-Zettler LA, Sogin ML, Gast RJ. 2014. Comparison of bacterial communities in sands and water at beaches with bacterial water quality violations. *Plos ONE.* 9(3): 1-9.
- Johnson JR, Stell AL. 2000. Extended virulence genotypes of *Escherichia coli* strains from patients with urosepsis in relation to phylogeny and host compromise. *J Infect Dis.* 181(1): 261-272.
- Simoes FF, Poirel L, Da Costa PM, Nordmann P. 2010. Seagulls and beaches as reservoirs for multidrug-resistant *Escherichia coli*. *Emerg Infect Dis.* 16(1): 110-112.
- Yang K, Pagaling E, Yan T. 2014. Estimating the prevalence of potential Enteropathogenic *Escherichia coli* and intimin gene diversity in a human

# Expression, Purification, and Crystallization of an Endoxylanase from *Bacteroides Vulgatus*

Jesslyn Park

Jason Hurlbert, Ph.D. (Mentor)

This work was also supported by SC-INBRE and the Winthrop University Department of Chemistry, Physics, and Geology

## ABSTRACT

Sustainable sources of energy are growing in demand as fossil fuels are rapidly expended. One such energy source is fuel ethanol generated from the fermentation of plant biomass by engineered bacterial biocatalysts. The creation of a biocatalyst capable of converting nearly any plant matter to fuel ethanol requires the identification of novel enzymes capable of degrading specific carbohydrate polymers and cloning these enzymes into a bacterial host. This study seeks to structurally characterize a novel xylanase of glycosyl hydrolase family 30 (GH30) from *Bacteroides vulgatus*, a bacterium found in the human gut microbiome, via x-ray crystallography. The gene for *B. vulgatus* GH30 endoxylanase (BvGH30) was cloned into a pET 28b prokaryotic expression vector which was used to transform a culture of *Escherichia coli*, and the resulting bacterial strain was used to express the cloned BvGH30 gene. The recombinant protein produced was then purified to homogeneity via Ni<sup>2+</sup>-Metal Chelating Affinity Chromatography (MCAC) as determined by sodium dodecyl sulfate polyacrylamide gel electrophoresis (SDS-PAGE). The purified protein was concentrated to 10 mg/mL and used to screen for solution conditions that promoted crystal growth by sparse matrix screening in hanging drop, vapor-diffusion plates. Single rectangular crystals of defined morphology (less than 0.1mm in length) were obtained in 0.2M (NH<sub>4</sub>)<sub>2</sub>HPO<sub>4</sub>, 20% (w/v) PEG 3350, pH 8.0 and large numbers of smaller rectangular crystals were obtained in 0.1M Citric acid, 0.8M (NH<sub>4</sub>)<sub>2</sub>SO<sub>4</sub>, pH 4.0. Grid screening around these two conditions will be employed to increase crystal size and all crystals larger than 0.1mm in length will be subjected to x-ray diffraction analysis.

## INTRODUCTION

As non-renewable energy resources are depleted at an alarming rate, and some researchers predicting fossil fuel reserves to be consumed within the next hundred years (Shafiee & Topal, 2009), alternate, sustainable sources of energy are being sought with increasing urgency. Plant biomass has been used for over a decade as one such renewable energy source, however its use is not without problems. Specifically, current implementation of plant biomass for energy production has revolved around the utilization of “low hanging fruit” or the easiest to use components of plant tissue, such as corn kernels or sugar cane juice. The easily fermentable glucose found in these materials is converted to fuel ethanol by microbial biocatalysts. Unfortunately, the diversion of these materials from animal and human food processing streams ultimately

results in decreased availability of food for lesser-developed countries (Runge & Senauer, 2007). In order to minimize the impact of using possible foodstuffs as substrate for fuel ethanol production, researchers have begun turning their attention to seldom-used polysaccharide materials currently discarded as waste. Materials like sugar cane bagasse and corn stalks contain up to 30% hemicellulose. Hemicellulosic biomass contains polymers of xylose (xylans) and galacturonic acid (pectins). The development of biocatalysts that can ferment these materials relies upon the discovery and characterization of enzymes capable of degrading the polymers to their component sugars, which can then be fermented to ethanol by the microbes.

Glycosyl hydrolases are enzymes that degrade polysaccharide polymers via the addition of a water molecule to the glycosidic

bond between monomeric units. Xylanases are enzymes that hydrolyze xylans, hemicellulosic polymers found in plant cell walls that are composed of  $\beta$ -xylose monomers linked via 1,4 glycosidic bonds. At present, endoxylanases are found in 3 distinct families of the glycosyl hydrolases (GH): GH family 10, GH Family 11 and GH Family 30. Each family of xylanase generates unique products during the hydrolysis of xylan substrates. Members of GH30 hydrolyze the glycosidic bond between glucuronic acid (GA) residues one position from the non-reducing terminus at the  $\beta$ -1,4 bond and requires the presence of  $\alpha$ -1,2-linked 4-O-methyl-D-glucuronic acid substituents for substrate recognition and anchoring by binding pocket residues of the xylanases (Hurlbert & Preston 2001; St John *et al.* 2011, Urbániková *et al.*, 2011).

Previous research suggests that binding pocket residues most significant to the catalytic function in glycosyl hydrolases are aspartate and/or glutamate (Davies & Henrissat, 1995). More recent studies have identified other critical catalytic residues, such as arginine, to be involved in optimal substrate positioning for hydrolysis via interaction with negatively charged hydroxyl groups of GA appendages, ultimately increasing catalysis efficiency (St John *et al.*, 2014; Urbániková *et al.*, 2011). However, a study of *Clostridium papyrosolves* of GH30 (CpXynA) by St John *et al.* (2014) found that while typically conserved, arginine is not critical to enzyme function. Although the lack of arginine, specifically in the  $\beta$ 8- $\alpha$ 8 loop, alters the shape of the binding pocket of the enzyme and lessens catalysis efficiency, the adjusted structure allows active site recognition of other hemicellulosic substrates such as xylooligosaccharides and arabinoxylans.

As part of our efforts to characterize novel GH30 xylanases, we are attempting to determine the x-ray crystallographic structure of 3 enzymes identified by bioinformatic searches of genomic databases. We have identified an endoxylanase of GH30 from *Bacteroides vulgatus* (BvGH30), an organism found in the human gastrointestinal tract. The amino acid sequence of the GH30 xylanase from *B. vulgatus* reveals the absence of the essential arginine residue in

the  $\beta$ 8-  $\alpha$ 8 loop region. Thus, in accordance with prior research, *B. vulgatus* is most likely able to hydrolyze GA, and possibly arabinoxylan and neutral xylooligosaccharides, though inefficiently (St John *et al.*, 2014). In this study, we seek to determine the 3-dimensional structure of the endoxylanase in order to understand the relationship between its structure and function of interest to biocatalysts development.

## MATERIALS AND METHODS

### *Bacterial Transformation of E. coli Rosetta 2*

To grow transformed bacterial colonies, 2 mL of *Bacteroides vulgatus* GH30 pET 28b plasmids were inserted into a micro-centrifuge tube containing 100 mL of *Escherichia coli* Rosetta 2. The centrifuge tube was then placed on ice for 10 minutes, into a water bath at 42° C for 2 minutes, and finally back on ice for 10 min. 500 mL of Luria-Bertani broth media was then added to the centrifuge tube, which was then incubated with shaking for 45 min at 37° C. After incubation, 100 mL of the aliquot was spread onto a plate containing agar that had been infused with antibiotics kanamycin and chloramphenicol. The plate was finally incubated at 37° C for 24 hours. Single colonies were cultured into flasks that each contained 100 mL of Luria-Bertani broth media and 100 mL of kanamycin and chloramphenicol. The flasks were incubated with shaking for 24 hours at 37° C. 1L flasks containing 1L of fresh media and 100mL of each antibiotic were then inoculated with 10mL of culture and incubated at 37° C for 3 hours.

### *Expression of BvGH30*

Once cultures reached optimal densities of 0.6 absorbance at 600nm, 0.1mM of Isopropyl  $\beta$ -D-1-thiogalactopyranoside was added to induce protein production. The cultures were incubated at 37° C with shaking for 24 hours. Cultures were transferred into 1L centrifuge tubes and centrifuged at 4,500 rpm for 10 minutes.

### *Cell Lysis of E. coli Rosetta 2*

Following the initial centrifugation, the supernatant was drained and the cell pellet was mixed with 5mL/g of lysis buffer. Sonification was conducted for 30 minutes at pulses of 15sec

per 45 seconds at 70 amperes. The mixture was then centrifuged at 15,000 rpm for 45 minutes, and the supernatant was collected.

#### *Purification of BvGH30*

Supernatant of cell lysis centrifugation was collected for chromatogram analysis with Ni<sup>2+</sup>-Metal Chelating Affinity Chromatography by injections of 50 mL. The UV detector read 280 nm to identify protein presence, and purification was facilitated by a 500mM imidazole buffer wash. The pure BvGH30 was then transferred into 22mm dialysis tubing with a MWCO of 10 kDa and dialyzed with 25mM HEPES and 150mM NaCl buffer over 48 hours. Protein was finally spin-concentrated to 10 mg/mL.

#### *SDS-PAGE of Samples from Each Step of Purification*

Of each product of the purification process, 20 mL of samples were mixed with 5 mL of 5X SDS-PAGE loading dye. The samples were heated on a heating block for 30 seconds. Run at 70 V, Precision Plus Protein™ Dual Color Standard by Bio-Rad was loaded onto the gel at volume 5 mL along with samples

loaded at 20 mL. Electrophoresis was ceased when the leading band of the standard reached the front edge of the gel. The gel was then stained for 24 hours and de-stained.

#### *Crystallization of BvGH30*

Concentrated pure protein was subjected sparse matrix screening of 280 conditions within Hampton Research Crystallization Screens as well as 50 by a Sigma Aldrich Biochemika Crystallization kit were employed utilizing hanging drop, methods. 750 mL of solution of each condition was injected into 24 well plates were used, then 2 mL of well solution and 2 mL of protein were micro-pipetted onto a coverslip that was finally inverted and sealed onto the well. Crystals were found to grow in 0.2M Ammonium phosphate dibasic pH 8.0 with 20% w/v Polyethylene glycol 3,350 as well as 0.1M Citric acid pH 4.0 and 0.8M Ammonium sulfate. In order to optimize the crystal size and regularity, a grid screen made of Ammonium Phosphate at basic pH's and Polyethylene glycol 3,350, successfully yielding crystals.

## RESULTS

### *BvGH30 Purification*

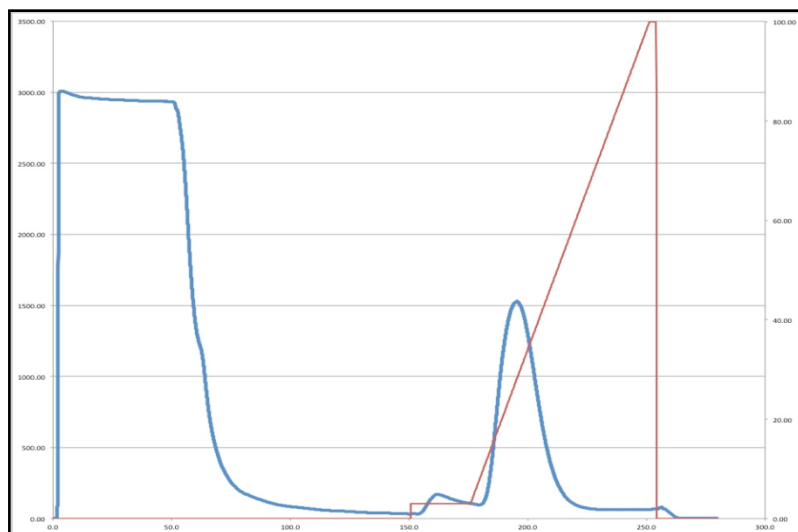
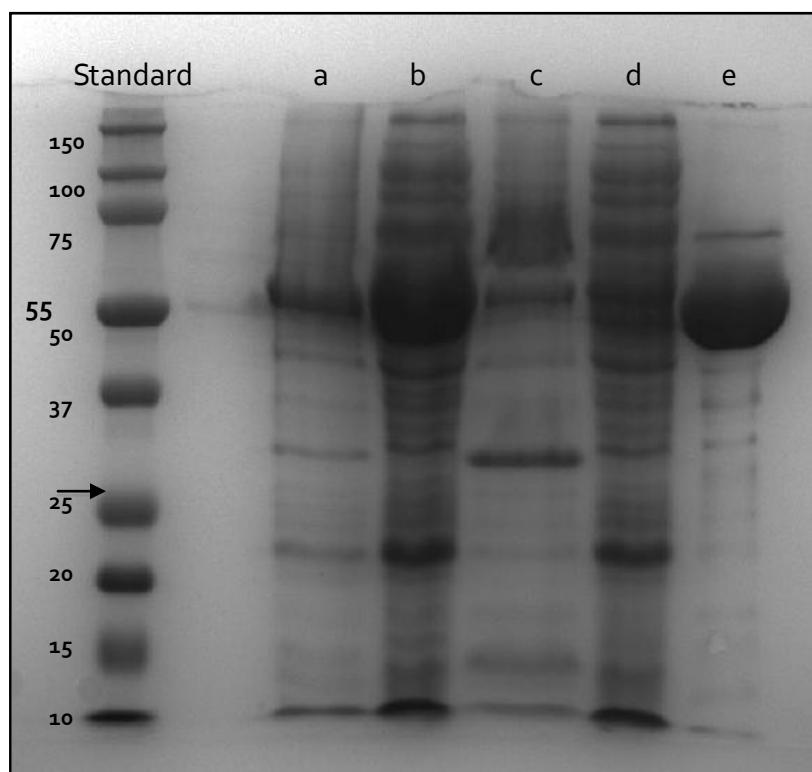

**Figure 1:** Chromatogram from Purification of BvGH30.

The blue peak of the chromatogram indicates where protein was detected upon elution from the column with 500 mM imidazole buffer. The eluted protein peak was then analyzed via SDS-PAGE gel to confirm identity and successful purification.



### *SDS PAGE of Each Step of Purification*



Lane *a* contains a sample of the cell pellet from the initial centrifugation. Lane *b* contains a sample of the lysate supernatant of the pellet from the second centrifugation. Lane *c* contains a sample from cell pellet of the second centrifugation. Lane *d* contains a sample from the flow through from chromatography. Lane *e* contains a sample from the peak fraction from chromatography.

**Figure 2:** SDS-PAGE gel of Each Step of Purification of BvGH30.

### *Crystallization: Sparse-Matrix Screening*

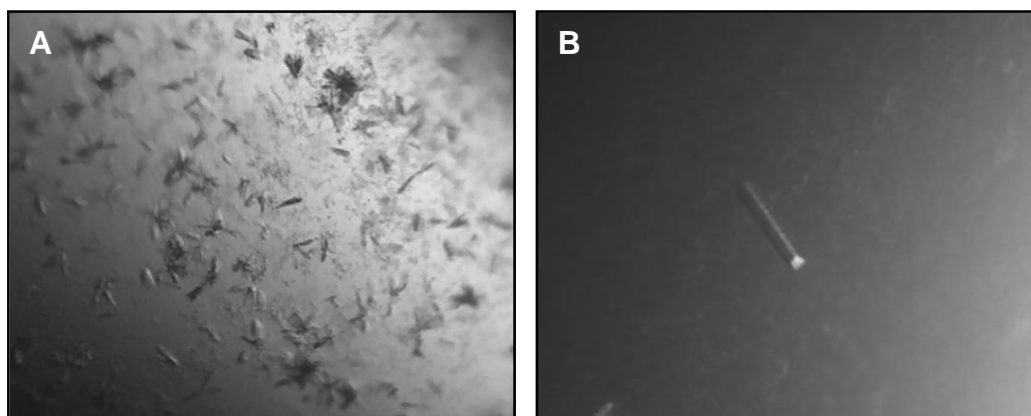

**Figure 3:** Initial Crystallization Trials of BvGH30

Figure 3A depicts crystals formed with 0.1M Citric acid pH 4.0 and 0.8M Ammonium sulfate. Figure 3B depicts crystals formed with 0.2M Ammonium phosphate dibasic pH 8.0 with 20% w/v Polyethylene glycol 3,350.

## Crystallization: Grid-screening

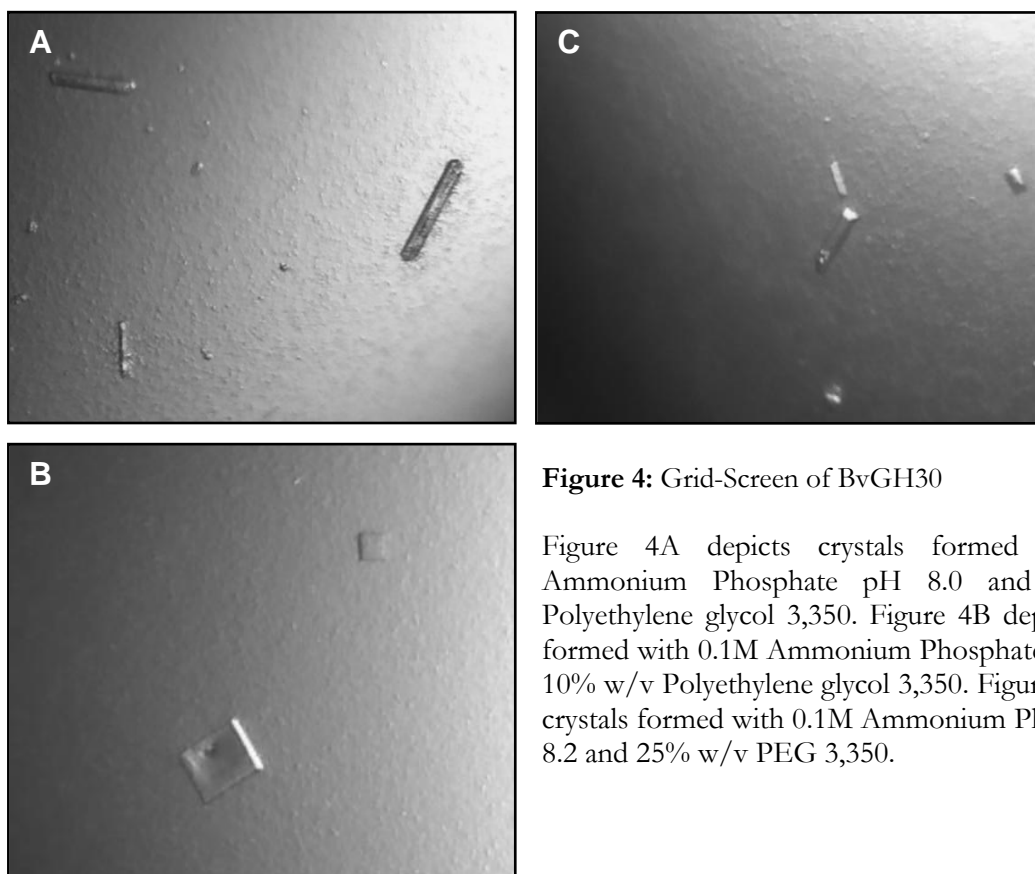

**Figure 4:** Grid-Screen of BvGH30

Figure 4A depicts crystals formed with 0.1M Ammonium Phosphate pH 8.0 and 20% w/v Polyethylene glycol 3,350. Figure 4B depicts crystals formed with 0.1M Ammonium Phosphate pH 8.4 and 10% w/v Polyethylene glycol 3,350. Figure 4C depicts crystals formed with 0.1M Ammonium Phosphate pH 8.2 and 25% w/v PEG 3,350.

## DISCUSSION

Pure protein was successfully eluted at 200 mL with a wash of 500mM imidazole buffer via its interception of hexa-histidine tags on BvGH30 (Figure 1). Purity was confirmed by SDS-PAGE where only protein of molecular weight  $\approx 55$  kDa, the weight of BvGH30, was revealed (Figure 2). Sparse matrix crystallization screens ensued and produced crystals under two conditions: in 0.2M  $(\text{NH}_4)_2\text{HPO}_4$ , 20% (w/v) PEG 3,350, pH 8.0 (Figure 3A) as well as 0.1M Citric acid, 0.8M  $(\text{NH}_4)_2\text{SO}_4$ , pH 4.0 (Figure 3B). The major trend identified between the two conditions is the presence of polyatomic anions: phosphate and sulfate. Thus, 0.1M  $(\text{NH}_4)_2\text{HPO}_4$  was used in grid screening, along with varied basic pH's as well as concentrations of PEG 3,350. Crystals were obtained from 0.1M  $(\text{NH}_4)_2\text{HPO}_4$  pH 8.0, 20% w/v PEG 3,350 (Figure 4A), 0.1M  $(\text{NH}_4)_2\text{HPO}_4$  pH 8.2, 25% w/v PEG 3,350 (Figure 4B), and 0.1M

$(\text{NH}_4)_2\text{HPO}_4$  pH 8.4, 10% w/v PEG 3,350 (Figure 4C). Although this grid screen did not yield crystals of adequate size ( $>0.1\text{mm}$ ), significance of polyatomic anions in crystallization of BvGH30 was confirmed, upon which future work can be conducted.

## FUTURE WORK

As the first round of grid screening produced crystals less than 0.1 mm in length, further crystal scoring as well as grid screening expanding upon conditions that employ polyatomic anions must be conducted. Once protein crystals of adequate size and regularity are acquired, crystals will be screened for x-ray diffraction data collection and the three-dimensional structure of BvGH30 will be determined.

## REFERENCES

- Davies, G. & Henrissat, B. (1995). Structures and mechanisms of glycosyl hydrolases. *Structure*, 3(9): 853-859.
- Hurlbert, J. C., & Preston, J. F. (2001). Functional characterization of a novel xylanase from a corn strain of *Erwinia chrysanthemi*. *Journal of bacteriology*, 183(6): 2093-2100.
- Runge, C. F. & Senauer, B. (2007). How biofuels could starve the poor. *Foreign affairs*, 41-53.
- Shafiee, S. & Topal, E. (2009). When will fossil fuel reserves be diminished? *Energy policy*, 37(1), 181-189.
- St John, F. J.; Dietrich, D.; Crooks, C.; Pozharski, E.; González, J. M.; Bales, E.; Smith, K.; Hurlbert, J. C. (2014). A novel member of glycoside hydrolase family 30 subfamily 8 with altered substrate specificity. *Biological Crystallography*: 70(11).
- St John, F. J.; Hurlbert, J. C.; Rice, J. D., Preston, J. F.; Pozharski, E. (2011). Ligand bound structures of a glycosyl hydrolase family 30 glucuronoxylan xylanohydrolase. *Journal of molecular biology*, 407(1): 92-109.
- Urbániková, L.; Vršanská, M.; Mørkeberg Krogh, K. B.; Hoff, T.; Biely, P. (2011). Structural basis for substrate recognition by *Erwinia chrysanthemi* GH30 glucuronoxylanase. *FEBS Journal*, 278(12): 2105-2116.

# Creating Narratives through Art as Self-Definition for Black Women

Shannon Snelgrove  
Laura Gardner, Ph.D. (Mentor)

## ABSTRACT

The purpose of this study was to examine ways in which Black female artists have created narratives through art as self-definition. These artists have responded to stereotypical stories and images of Black women by creating self-defined stories and images. This study specifically focused on Faith Ringgold because she has combined narrative and visual art in story quilts that present Black women as empowered, multidimensional people. Her story quilt *Who's Afraid of Aunt Jemima* reclaims the narrative of the stereotypical Black mammy character, Jemima. Ringgold depicts Jemima as a liberated, dynamic entrepreneur and family woman. In creating positive characterizations of Black women, Ringgold does not flatten her characters. They are rounded with all the complexities that come with being human.

Themes of self-definition were further investigated through narrative inquiry of biographies of twenty-five notable Black women artists of the twentieth century. The artists are from a variety of time periods within the twentieth century and include painters, sculptors, collage artists, fabric artists, and photographers. Their biographies were thematically analyzed. Findings showed that about half of the artists clearly intended to express self-definition through their art in response to stereotypes of Black women. The overwhelming majority of this half were not only concerned with creating an image of self, but also with depicting Black women in general in a positive light, illustrating them as diverse, complex people.

## BACKGROUND

Self-definition is especially important for Black women because they experience the intersecting oppressions of racism and sexism (Copeland, 1977), which both contribute to the creation and perpetuation of controlling images of Black womanhood (Collins, 2000). According to Collins (2000), rather than accepting these images, Black women have “crafted identities designed to empower them[selves]” (pp. 97-98).

Hood (2001) suggests there is a long tradition of Black women who have used the arts to express self-definition. Faith Ringgold (Figure 1), who makes story quilts telling her lived experience and larger stories of Black women (Koppman, 1991), stood out to me among the Black women artists I researched as the one who speaks most directly to the importance of self-definition through narrative and art.

In her story quilt, *Who's Afraid of Aunt Jemima* (Figure 2), Ringgold (1996) deals directly with a controlling image of Black

womanhood—Aunt Jemima (Figure 3). Aunt Jemima was a mammy figure used as the face of a pancake mix (Morgan, 1995). She existed beyond the box. Smith (1999) points out that “a systematic effort was made to give Aunt Jemima a personal history and make her a ‘real southern cook’” (p. 351). Aunt Jemima’s portrayal as a one-dimensional happy servant “obscured the reality of Black people’s lives” (Ritterhouse, 2009, p. 185). With her story quilt, Ringgold changes the narrative. She develops the protagonist, Jemima Blakey, as a multidimensional empowered businesswoman (Ringgold, 1996). Accordingly, Hudson (1995) suggests that “understanding the power of image to construe a social reality,” Black artists have taken on the work to “convey Black life more realistically” (pp. 136-137).

The identification of themes of self-definition in Faith Ringgold’s work led to narrative inquiry of stories of other Black women artists.



Figure 1



Figure 2



Figure 3

## METHODS

The methods for this study are based on narrative inquiry, which is “a way of understanding experience...the stories of the experiences that make up people’s lives...stories lived and told” (Clandinin & Connelly, 2000, p. 20). I applied narrative inquiry by reading and thematically analyzing biographies of twenty-five of the most prominent Black women artists of the twentieth century. These biographies came from “African American Women Artists,” a section of the book *Women Artists of Color: A Bio-Critical Sourcebook to 20<sup>th</sup> Century Artists in the Americas* (Farris, Kramer, & Wasserman, 1999). “This book attempts to provide a representative sample of older and/or deceased artists who helped pave the way for future generations; mature, midcareer mainstream artists with national/international reputations; and younger, emerging artists” (Farris, 1999, p. xiv). The artists include painters, sculptors, collage artists, fabric artists, and photographers.

I counted the number of the artists’ biographies that fit into two themes. The biography had to meet Theme One to be considered for Theme Two. Theme One is “artist rejects stereotypes and uses empowering images of self as a primary subject matter in her art.” Theme Two is “artist’s intention is not only to portray herself, but to portray Black women at large in a positive light.” For the theme to be counted, the biographer had to clearly state that theme; I did not leave it to my own interpretation.

## RESULTS

Out of the total of twenty-five artist biographies, thirteen fit Theme One: “artist rejects stereotypes and uses empowering images of self as a primary subject matter in her art.” Out of the thirteen biographies that fit Theme One, twelve fit Theme Two: “artist’s intention is not only to portray herself, but to portray Black women at large in a positive light.”

Themes found in biographies of 25 of the most prominent Black women artists of the 20 <sup>th</sup> century	
Theme	Number of biographies
1. Artist rejects stereotypes and uses empowering images of self as a primary subject matter in her art.	13 out of 25
2. Artist’s intention is not only to portray herself, but to portray Black women at large in a positive light. (Must meet Theme One in order to be considered for Theme Two.)	12 out of 13

## DISCUSSION

Considering the endless variety of subject matters that art can contain, the fact that thirteen out of twenty-five of the artists actively rejected stereotypes and used empowered images of self as a primary subject matter is significant. The overwhelming majority of the artists who used images of self as a primary subject matter did so not only to portray themselves, but also to convey a positive image of Black women as a whole. These artists have created their own sense of self via artistic narratives, and have also attempted to redefine the identity of their people.

It may seem counterproductive for one to attempt to define the identity of Black people as a whole in the name of self-definition. However, the artists represented in this research did not declare a single overarching Black identity. They presented complex narratives of multidimensional Blackness. They did not attempt to box people into one identity; they offered many possibilities of what Blackness can look like in response to pervasive stereotypical narratives.

This research is a starting point for further inquiry into the empowerment of women and people of color through art. Through this project, I have been exposed to concerns, challenges, and intentions of artists who use their art as a medium of self-definition. I am now prepared to interview, survey, and

hold focus groups with contemporary women artists and artists of color who make self-definition a primary focus of their work.

by M.M. Manning. *The Journal of Interdisciplinary History*, 30(2), 350-352.

### REFERENCES

- Clandinin, D.J., & Connelly, F.M. (2000). *Narrative inquiry: Experience and story in qualitative research*. San Francisco: Jossey-Base Publishers.
- Collins, P.H. (2000). The power of self-definition. In *Black feminist thought* (pp. 97-121). New York: Routledge.
- Copeland, E. J. (1977). Counseling Black women with negative self-concepts. *Personnel & Guidance Journal*, 55(7), 397-400.
- Farris, P. (1999). Introduction. In P. Farris (Ed.), *Women artists of color* (pp. xiii-xx). Westport, CT: Greenwood Publishing Group, Inc.
- Farris, P., Kramer, K., & Wasserman, N. (1999). African American women artists. In P. Farris (Ed.), *Women artists of color* (pp. 231-371). Westport, CT: Greenwood Publishing Group, Inc.
- Hood, Y. (2001). The culture of resistance: African American art quilts and self defining. *Uncoverings*, 22, 141-169.
- Hudson, B.A. (1995). Images used by African-Americans to combat negative stereotypes. In H.W. Harris, H.C. Blue, & E.E.H. Griffith (Eds.), *Racial and ethnic identity* (pp. 135-172). New York: Routledge.
- Koppman, D. (1991). Odyssey of Faith. *Woman's Art Journal*, 12(2), 40-42.
- Morgan, J. (1995). Mammy the huckster: Selling the old south for the new century. *American Art*, 9(1), 86-109.
- Ringgold, F., Freeman, L., & Roucher, N. (1996). *Talking to Faith Ringgold*. New York: Crown Publishers.
- Ritterhouse, J. (2009). Reviewed work: Clinging to mammy: The faithful slave in twentieth-century America by Micki McElya. *The Journal of Southern History*, 75(1), 184-185.
- Smith, G.L. (1999). Reviewed work: Slave in a box: The strange career of Aunt Jemima



# Creating a microcosm to examine salinity tolerance of *Escherichia coli* in beach sand

Leigha Stahl

Victoria Frost, Ph.D. (Mentor)

Matthew Heard, Ph.D. (Mentor)

## ABSTRACT

*Escherichia coli* (*E. coli*) is a gram-negative bacteria species that thrives in a variety of environments around the world. Due to its widespread prevalence, it is commonly used as an indicator for fecal pollution and other pathogens. One place where it is not often looked for is oceanic beaches because *E. coli* is inhibited by salt. However, recent research has shown that *E. coli* often thrives in sand at many oceanic beaches. To determine how it persists in sand, we created a microcosm simulating the intertidal zone of an oceanic beach. Using this microcosm, we examined how varying levels of salinity (0-6‰) affect the persistence of *E. coli* in these sandy environments. We found that there was a negative correlation between increasing salinity and the most probable number of *E. coli* colony forming units, which suggests that *E. coli* is being inhibited by salinity to a degree. However, we still found that *E. coli* was able to persist at all salt concentrations including those that exceed normal oceanic salinity. Collectively, our findings suggest that *E. coli* may be able to persist on sandy beaches despite the stress of salinity and may be a useful tool in the future for assessing these ecosystems for fecal contamination levels.

## INTRODUCTION

*Escherichia coli* (*E. coli*) are gram-negative bacteria that are typically found in the intestinal tract of endotherms where they can thrive in warm, moist conditions. *E. coli* has also been shown to persist outside of the host in varying environments (Boehm et al. 2009a) and is commonly considered to be a fecal indicator bacteria (FIB) because it can be used to measure the presence of fecal matter and indicate potential signs of pollution (Halliday et al. 2014). The presence of *E. coli* can also be used to signal potential pathogenic bacteria (Halliday et al. 2014). Due to *E. coli*'s association with pathogenic bacteria and fecal material, *E. coli* can be used as an important tool to assess ecological quality and sanitation (Brady et al. 2014).

One environment in which *E. coli* are commonly found includes oceanic beaches. Because the *E. coli* no longer persist in the constantly warm and moist environment of the intestinal tract, they face many stressors that can threaten their survival. Several of these stressors include temperature variation due to seasonal and daily changes, microbial competition, and

ultraviolet radiation from the sun (Halliday et al. 2014; Whitman et al. 2014). While temperature and sunlight influence *E. coli* growth, salinity has shown to be a major factor for the inhibition of *E. coli* growth (How et al. 2012; Ortega et al. 2009). Salinity, an important stressor at oceanic beaches, can inhibit the growth and survival of *E. coli* (Ortega et al. 2009). Due to the inhibition of *E. coli* by salt, the growth of *E. coli* at oceanic beaches where ocean water has a 3‰ salinity was thought to be hindered. However, our research and previous research has shown that *E. coli* can tolerate salinity and persist in oceanic environments where the salinity levels exceed typical oceanic salt concentrations (Ortega et al. 2009; How et al. 2012; Lewis et al. in prep). In previous studies, *E. coli* strains have been shown to be able to persist in high NaCl concentrations after multiple generations and that suggests that *E. coli* may be able to become increasingly halophilic over time (Lee et al. 2012; How et al. 2013).

One potential issue that arises from *E. coli*'s perceived lack of salinity tolerance is that the Environmental Protection Agency (EPA) does not test for *E. coli* on oceanic beaches

(EPA 2014). While the persistence of *E. coli* in freshwater sand is documented, limited research on the salinity tolerance of *E. coli* in beach sand exists (but see Yamahara et al. 2012). Testing of *E. coli* on oceanic beaches may provide greater insight into health and safety protocols for marine and beach recreation.

In our study, we created a microcosm of the intertidal beach zone to simulate the natural environment where *E. coli* can thrive as well as assess how *E. coli* can persist in a sandy environment with varying levels of salinity. Our goal is to better understand how salinity affects growth and persistence of *E. coli* in beach sand.

## METHODS

An intertidal microcosm was created in order to simulate oceanic conditions and test the salinity tolerance of *E. coli* in intertidal sand at varying levels of salinity (0%-6% NaCl). Oceanic salinity levels range from around 3-4% NaCl, and the salinity level at Folly Beach, SC, is normally 3.8% (Heard, personal observation).

### *Microcosm Experimental Set-up*

We set up an intertidal microcosm with sterilized materials using 96.25g of play grade sand that was placed in 600mL beakers. The play grade sand was sterilized using high heat from a drying oven. Following the addition of sterilized sand, nutrient broth with varying salt concentrations (0-6%) and a standard amount of *E. coli* was added. To obtain standardized levels of *E. coli*, we created a McFarland Standard (1.5 X 10<sup>8</sup>CFU/mL) (ThermoScientific Remel™, KS, USA 2015) of K-12 *E. coli*, a commonly used lab strain. We diluted the McFarland standard and added 1μL to 25mL of nutrient broth, which was mixed with varying concentrations of salt (NaCl; 0%-6%) and replicated in triplicate. The resulting mixture of nutrient broth inoculated with K-12 *E. coli* was placed onto the sterile sand. The sand and broth was mixed by swirling the beaker until the sand was saturated to simulate the intertidal beach region.

### *Bacteria Extraction & Incubation*

*E. coli* was extracted from sand after 0 hours and 6 hours of bacteria deposition to determine the change in *E. coli* growth in response to salinity. *E. coli* was extracted by removing 7.0g of sand via a sterilized spatula and placing it into 35mL of water. The mixture was then shaken for two minutes and allowed to settle for 30 seconds (Boehm et al. 2009b; Velonakiset al. 2014). For each mixture, 300μL was micropipetted into each well of a 96-well Coliplate in triplicate for each salinity concentration. Coliplates were incubated for 48 hours at 37°C.

### *E. coli Enumeration*

After incubation for 48 hours at 37°C, the blue wells of the Coliplate were counted (Bluewater Biosciences Inc., Mississauga, ON, Canada 2015). Subsequently, the fluorescent wells were recorded using an ultraviolet light. The fluorescent well amount for each Coliplate was correlated to the most probable number (MPN) of *E. coli* colony forming units per 100mL.

### *Analysis*

We examined whether salinity inhibited the growth of *E. coli* using linear regression analysis. We analyzed changes in the abundance of *E. coli* over the six hours using ANOVA and Pairwise t-tests.

## RESULTS

Salinity had a significant effect on the growth of *E. coli*. As the salinity concentration increased in the intertidal microcosm, the change in the MPN of *E. coli* colony forming units decreased (Graph 1). We observed a significant decrease in the amount of *E. coli* with increasing concentrations of salinity between 0 and 6 hours. Our pairwise t-tests also indicate that as salinity increases, the change in the MPN of *E. coli* colony forming units decreases; our results indicate that there are three distinct regions of *E. coli* levels between 0%-6% salinity between 0%-1%, 2%-3%, and 3%-6% (Graph 2).

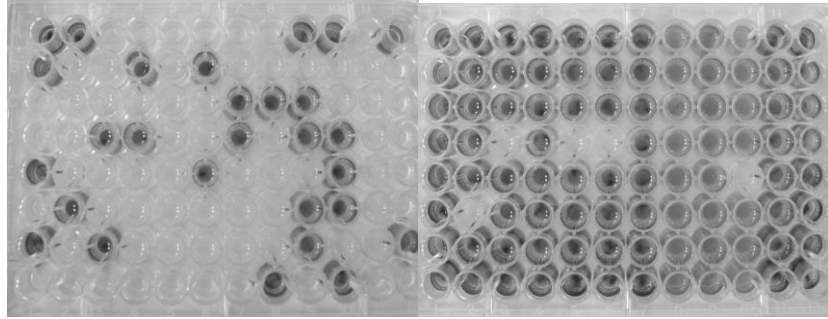

**Figure 4.** (A) contains 1% salinity at 0hr. (B) contains 1% salinity at 6 hours. As shown, there is an increase in blue wells and MPN (most probable number) of *E. coli* at this low concentration of salinity.

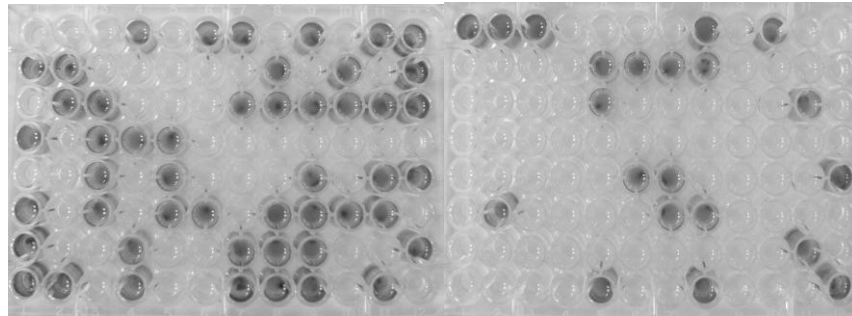

**Figure 5.** (A) contains 6% salinity at 0hr. (B) contains 6% salinity at 6 hours. There is a decrease in blue wells and MPN of *E. coli* at this higher concentration of *E. coli*.

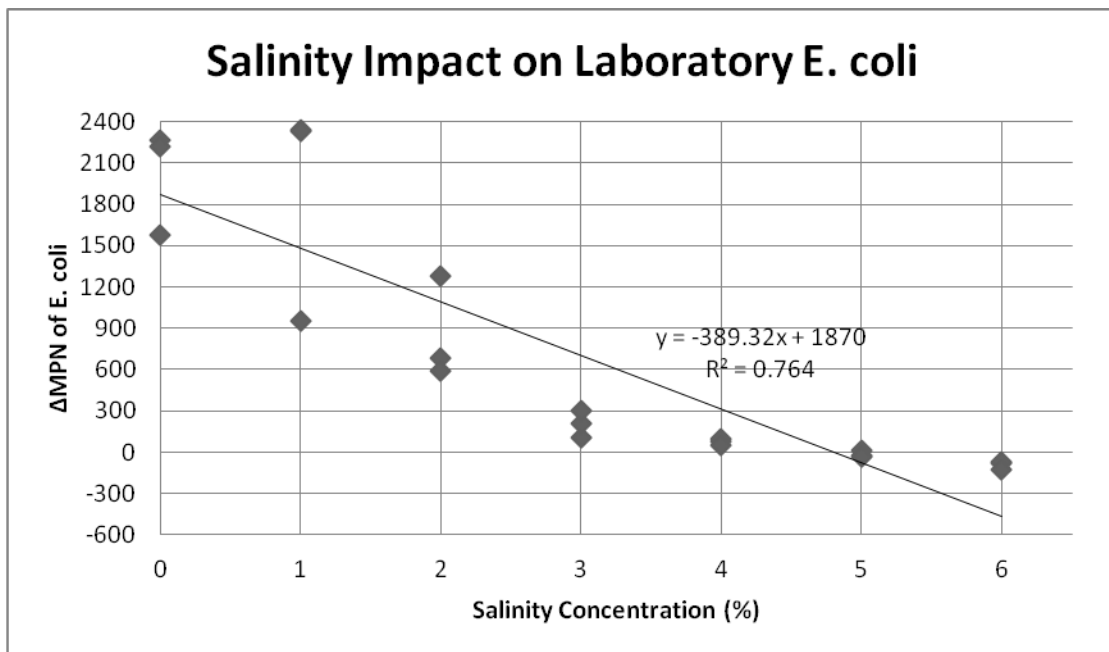

**Graph 1.** We observed a significant effect of salinity concentration on the growth of *E. coli* ( $R^2=0.764$ ;  $p<0.0001$ ). Our linear regression analysis showed that the inhibition of *E. coli* growth increased as salinity concentration increased; a negative correlation was observed.

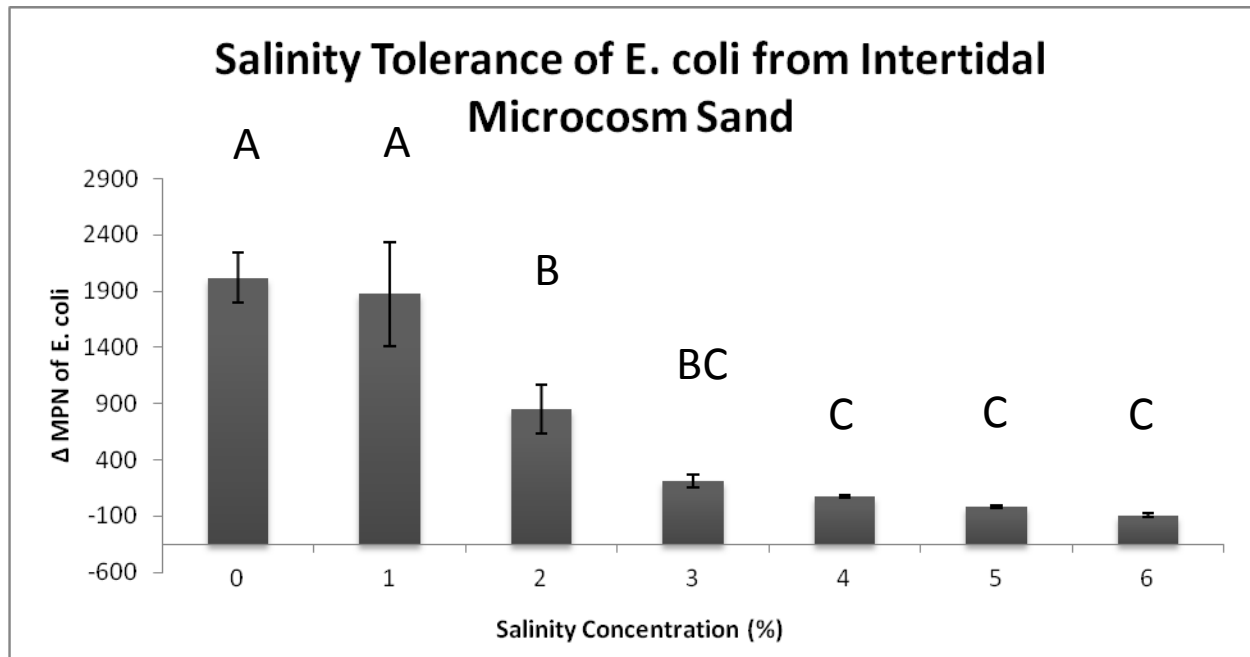

**Graph 2.** We observed a significant effect of salinity concentration on the growth of *E. coli* ( $F_{6,14}=18.2553$ ;  $p<0.0001$ ). Our Pairwise t-tests showed that the higher oceanic salinity concentrations (4-6%) were significantly different than the lower salinity levels (0-2%).

## DISCUSSION

We found that *E. coli* is capable of surviving at salinity levels greater than present (approximately 3-4% NaCl) in most oceanic ecosystems. Although *E. coli* growth was inhibited by increased salinity as suggested by the decrease in the change in the number of MPN of *E. coli* forming units, *E. coli* persisted at salinity levels greater than 4%, which is the salinity of the ocean. Our microcosm findings imply that *E. coli* is capable of persisting on oceanic beaches in beach sand. As suggested by previous research, *E. coli* may undergo halophilization in which after several generations of exposure to saline conditions, bacteria can develop higher salinity tolerance levels (How et al. 2013). Because oceanic *E. coli* are continuously exposed to salinity, salinity tolerance may have resulted, allowing the persistence of *E. coli* growth and reduced inhibition.

Our findings also suggest that when health agencies like the EPA test for fecal contamination on oceanic beaches, they may want to consider including tests for *E. coli*. Rather than solely testing water for *E. coli*

contamination, levels of *E. coli* in sand should also be evaluated. Previous studies testing marine beaches suggest that the bacterial composition of marine water and sediment host different bacteria (Halliday et al. 2014). Not only are *E. coli* present in beach sand, but the sand may act as a bacteria reservoir and provide protection from UV radiation in marine environments (Beverdorf and Bornstein-Forst 2006). Because oceanic marine sand serves as a reservoir for *E. coli* and other associated enteric bacteria, *E. coli* testing is also important due to *E. coli*'s potential for pathogenicity. While the majority of *E. coli* bacteria are harmless, some *E. coli* can cause disease. An example is pathogenic *E. coli* O157:H7, which produces an enterotoxin that can cause diarrhea and gastrointestinal upset (Whitman et al. 2014; Yamahara et al. 2012).

In future studies, environmental isolates of *E. coli* could be used in our intertidal microcosm to assess their levels of salinity tolerance. Because environmental isolates of *E. coli* are constantly exposed to salinity levels, the bacteria may have a higher tolerance for salt

conditions than the K-12 lab *E. coli*. Further research may include microcosm testing of other beach zones, environmental *E. coli* strains, and temperature. Other beach zones that may be tested in a microcosm include the dune and subtidal zones. The combination between moisture and salinity of sand may play a role in *E. coli* survival. Previous research suggests that the intertidal region exhibits more *E. coli* growth than the subtidal sand region (Abdelzaher et. al 2009). While moisture or salinity may not account for this difference, the salinity levels amongst these regions may differ as the water evaporates from the sand, possibly influencing the salt concentration.

This work represents an important step in assessing *E. coli*'s ability to persist in oceanic beach environments. Furthermore, it suggests that testing sand in addition to water for the presence of *E. coli* is essential for identifying beaches that may be impacted by pollution and other pathogens.

## REFERENCES

- Abdelzaher AM, Wright ME, Ortega C, Solo-Gabriele HM, Miller G, Elmir S, Newman X, Shih P, Bonilla JA, Bonilla TD, Palmer CJ, Scott T, Lukasik J, Harwood VJ, McQuaig S, Sinigalliano C, Gidley m, Plano LRW, Zhu X, Wang JD, Fleming LE. 2010. Presence of Pathogens and Indicator Microbes at a Non-Point Source Subtropical Recreational Marine Beach. *Appl. Environ. Microbiol.* 76(3): 724-732.
- Alm EW, Burke J, Spain A. 2003. Fecal indicator bacteria are abundant in wet sand at freshwater beaches. *Water Research.* 37(16): 3978-3982.
- Alm EW, Burke J, Hagan E. 2006. Persistence and potential growth of fecal indicator bacteria, *Escherichia coli*, in shoreline sand at Lake Huron. *J. Great Lakes Res.* 32(2): 401-405.
- Beversdorf LJ, Bornstein-Forst SM, McLellan SL. 2006. The potential for beach sand to serve as a reservoir for *Escherichia coli* and the physical influences on cell die-off. *J. Appl. Microbiol.* 102(5): 1372-1381.
- Bluewater Biosciences Inc. 2015. Mississauga, ON, Canada. <[http://bluewaterbiosciences.com/index.php?main\\_page=product\\_info&products\\_id=1](http://bluewaterbiosciences.com/index.php?main_page=product_info&products_id=1)>.
- Boehm AB, Ashbolt NJ, Colford Jr JM, Dunbar LE, Fleming LE, Gold MA, Hansel JA, Hunter PR, Ichida AM, McGee CD, Soller JA, Weisberg SB. 2009a. A sea change ahead for recreational water quality. *J. Water Health.* 7(1): 9-20.
- Boehm AB, Griffith J, McGee C, Edge TA, Solo-Gabriele HM, Whitman R, Cao Y, Getrich M, Jay JA, Ferguson D, Goodwin KD, Lee CM, Madison M, Weisberg SB. 2009b. Faecal indicator bacteria enumeration in beach sand: a comparison study of extraction methods in medium to coarse sands. *J. Appl. Microbiol.* 107(5): 1740-1750.
- Brady A, Bushon N, Francy D, Myers D, Stoeckel D. 2014. Fecal Indicator Bacteria. USGS Science for a Changing World. <[http://water.usgs.gov/owq/FieldManual/Chapter7/7.1\\_ver2.1.pdf](http://water.usgs.gov/owq/FieldManual/Chapter7/7.1_ver2.1.pdf)>.
- EPA United States Environmental Protection Agency. 2014. Region 1: EPA New England. <<http://www.epa.gov/region1/eco/beaches/qa.html>>.
- Gobet A, Böer SI, Huse SM, van Beusekom JEE, Quince C, Sogin ML, Boetius A, Ramette A. 2012. Diversity and dynamics of rare and of resident bacterial populations in coastal sands. *Int. Soc. Microb. Eco.* 6: 542-553.
- Halliday E, McLellan SL, Amaral-Zettler LA, Sogin ML, Gast RJ. 2014. Comparison of bacterial communities in sands and water at beaches with bacterial water quality violations. *PLoS ONE.* 9(3): e90815. doi: 10.1371/journal.pone.0090815
- How JA, Lim JZR, Goh DJW, Ng WC, Oon JSH, Lee KC, Lee CH, Ling MHT. 2013. Adaptation of *Escherichia coli* ATCC 8739 to 11% NaCl. *Dataset Papers in Biology.* 1-7. <http://dx.doi.org/10.7167/2013/219095>

- Johnston KK, Dorsey JH, Saez JA. 2015. Stratification and loading of fecal indicator bacteria (FIB) in a tidally muted urban salt marsh. *Environ. Monit. Assess.* 187(58): 1-19.
- Lee CH, Oon JSH, Lee KC, Ling MHT. 2012. *Escherichia coli* ATCC 8739 adapts to the presence of sodium chloride, monosodium glutamate, and benzoic acid after extended culture. *ISRN Microbiology.* 1-10. doi:10.5402/2012/965356
- MacTavish RM, Cohen RA. 2014. A simple, inexpensive and field relevant microcosm tidal simulator for use in marsh macrophyte studies. *Appl. Plant Sci.* 2(11): 1-6.
- Ortega C, Solo-Gabriele H, Abdelzaher A, Wright M, Deng Y, Stark L. 2009. Correlations between microbial indicators, pathogens, and environmental factors in a subtropical Estuary. *Marine Pollution Bulletin.* 58:1374–1381.
- Thermo Fisher Scientific Inc. *Thermo Scientific Remel™*. 2015. KS, USA. <<http://www.thermoscientific.com/content/tfs/en/product/remel-mcfarland-equivalence-turbidity-standards.html>>.
- Velonakis E, Dimitriadi D, Papadogiannakis E, Vatopoulos A. 2014. Present status of effect of microorganisms from sand beach on public health. *J. Coastal Life Med.* 2(9): 746-756.
- Whitman, RL, Harwood VJ, Edge TA, Nevers MB, Byappanahalli M, Vijayavel K, Brandão J, Sadowsky MJ, Alm EW, Crowe A, Ferguson D, Ge Z, Halliday E, Kinzelman J, Kleinheinz G, Przybyla-Kelly K, Staley C, Staley Z, Solo-Gabriele HM. 2014. Microbes in beach sands: integrating environment, ecology and public health. *Rev. Environ. Sci. Biotechnol.* 13(3): 329-368.
- Yamahara KM, Sassoubre LM, Goodwin KD, Boehm AB. 2012. Occurrence and persistence of bacterial pathogens and indicator organisms in beach sand along the California coast. *Appl. Environ. Microbiol.* 78(6): 1733-1745.

#### ACKNOWLEDGEMENTS

I would like to thank the Winthrop McNair Scholars Program for their help and support. I would also like to thank my mentors for their time and expertise in the completion of this experiment as well as my lab colleagues.

# The Case of Affirmative Action in Undergraduate Admissions: United States and Brazil

Taylor Toves  
Adolphus Belk, Jr., Ph.D. (Mentor)

## ABSTRACT

In the realm of higher education, Affirmative Action has been a matter of dispute amongst college administrations, state legislatures, and even the Supreme Court of the United States. Affirmative Action was created in order to help ensure that underrepresented groups have a fair chance at obtaining a college education. This has not only affected colleges and universities in the United States but also Brazil. This research did a cross-country comparative analysis of two nation states that possess a similar history when it comes to race relations and how that has affected the condition of equity in higher education. Though both countries have had similar histories, the story of affirmative action has played out in very different ways. This research showed that while affirmative action has been established as a proper way to address historical wrong-doings for certain groups of people, that notion has not yielded the same results in the United States. The United States chose to take a more conservative political and judicial approach when examining the use of affirmative action for college and university admissions. Affirmative action has gradually deteriorated over the years in the United States and will continue to deteriorate, while still progressing and continuing in Brazil.

## INTRODUCTION

Race and race relations vary among countries, but in some instances are very similar. In the case of Brazil and the United States, race has been a factor that has influenced and shaped both societies from their founding until present day. This is especially apparent when it comes to the affirmative action debate. The intent of affirmative action in both nations is to bring equity and opportunity. There are several ways in which affirmative action is defined but in essence, it is a program to aid racial and ethnic minorities that have been historically disadvantaged and oppressed.

Affirmative action in both Brazil and the United States is both innovative yet extremely controversial, particularly in the case of university or college admissions. These programs tend to aim at African Americans and minorities in the United States and Afro-Brazilians, indigenous, and other darker skinned peoples in Brazil. The ongoing issue remains in both countries: who should reap the benefits of affirmative action and is this type of program a step backward in remedying racial discrimination? These countries have

approached this program in different ways and the program has continued to both advance but also face some challenges. The purpose of this literature review is to acknowledge the research that has been done by various scholars in the area of affirmative action that use race in the determination of college admissions in Brazil and the United States. The research question this comparative analysis hopes to give some theoretical sustenance to is: Through the comparative analysis of affirmative action programs for undergraduate admissions in Brazil and the United States, what are the conditions or circumstances under which affirmative action can be successful or will become dismantled in both countries?

In order to examine these research questions further, a theoretical framework is helpful in understanding why these countries operate in the way that they do. When trying to understand affirmative action in both Brazil and the United States, it is important to get a better grasp on the historical significance of race relations and racism in their respective countries. There are a few theoretical frameworks that can be used as a lens in which

to look at race and how it developed in these countries comparatively and independently. Political Scientist Mack Jones explores the theory of dominant-subordinate. He explained that too often there are theories such as the “melting-pot” theory, which does not frame the conversation of black politics in a constructive and progressive way. Jones believes that the most effective way in which to understand and look at black politics is the dominant-subordinate theory. This theory comes from the idea of a power struggle between two groups. Jones theorizes that the arena of black politics is an addition to the universal struggle for power (Jones 2014). The way in which this power struggle typically works in politics is that one group is fighting for policies, which will enable them to keep their position of power, whereas the other group is fighting for policies that will enable them to move from the position in which they are in. Blacks in the United States are in the subordinate group because of their ancestry and the history of their people being treated as less than or not equal. Whites in the United States are put into the dominate group because of their European ancestry in which their ancestors have always held the position of privilege and taking away rights from others in order to maintain their privilege. Jones defines a pattern in which both dominant and subordinate groups go from moderate positions on policies that will affect blacks and other non-white groups, to extremely radical. These pattern are helpful in understanding why certain groups act the way they do. For example, when there were policies that were being proposed discussing integration, there were some white Americans who were for it, but there were a large majority who were very much against it. They were against it because if integration occurs that means African Americans and other non-white Americans, the subordinate group, are one-step closer to moving up from the subordinate position to an equal stature. Jones’ work is especially helpful in understanding why racism still plays a large role both socially and politically in every institution in society.

In Brazil, race and racism plays out in a slightly different way, yet remains similar in some ways. Scholars, such as Anthony Marx

(1998), who studies nations comparatively such as the United States and Brazil, explained that since Brazil ended slavery, the country has been established under a false sense of racial unity. Brazil’s main goal after slavery was abolished was to establish a sense of nationalism and unity. Brazilian government officials did not create laws that excluded other races besides the white Brazilians in order to avoid conflict. So while Brazil has never had any formal laws that explicitly discriminated against other races; the culture itself is full of discrimination. Brazil’s racism has never been as transparent as the United States.

These various frameworks draw attention to the main themes that are used to describe racism and the conditions of race in both the United States and Brazil. Each of these theories can only help us understand some parts of affirmative action in both countries. In order to have a well-rounded perspective of how racism affects institutions and the people apart of these institutions, through programs such as affirmative action, the use all of these theories collectively is necessary. Race is a systemic and institutional construct and has continued to shape institutions in both countries presently. Ultimately, racism is a continuous power struggle between races that believe they are superior and want to remain dominant, while other races are suffering due to the other race’s quest for domination and power.

## METHODS

This project uses a qualitative comparative in-case analysis. This type of analysis enables analysts to provide a certain thickness or depth that quantitative research cannot fully grasp. There is a lot of value in studying a small number of cases. A thick description of the material for a small number of cases, rather than large, allows for more detail about why a certain phenomenon is happening, how that phenomenon came to be, and allows for predictions about what may happen in the future. This method is especially useful for my particular case.

The cases that I chose were the United States and Brazil. The United States and Brazil are usually studied together in comparative



politics because they are large multi-racial societies that have long standing issues with racism. They are very similar in the context that both nations struggle with racial domination; however they are different due to the way they have been handling this issue politically. It is hard to understand how two countries who had very similar historical beginnings with racism end up with different outcomes; in this instance affirmative action. That is why using qualitative comparative in-case methodology is the best fit for this project. Again, by really getting the details and tracing the history of race relations in each country, it helps piece together why things are playing out the way that they are.

This study focuses on affirmative action within higher education in Brazil and the United States, more specifically, undergraduate admissions. Affirmative Action is a policy that was developed to provide equality through institutions such as employment and education. Affirmative Action is something that both nations use in each of their countries, but they have taken different directions in the way that it operates. In the United States there has been a wave of support and opposition to it and has always been strongly against quotas. Whereas Brazil has opted for using quotas in their affirmative action policy. This study hopes to provide some insight as to why these countries have taken very different approaches towards affirmative action and what affirmative action may look like in the future for each country.

Even though this study is using a qualitative approach, there are a few disadvantages. One of the disadvantages of using this approach is that it cannot necessarily be generalized to other cases. However for the purpose of this project a qualitative route is more beneficial. The limits of a quantitative approach for this project is that it is difficult to quantify thoughts and thought processes. It would be hard to put into numbers why individuals think the way that they do. Qualitative methods allows room for exploration into those things that cannot be really explained numerically. That is why the methodology for this particular case is the best fit.

Affirmative action first began in the United States as an initiative to provide equal opportunity when it came to employment: Executive Order 10925 in 1961. Executive Order 10925 was enacted by President John F. Kennedy to enhance the equality of job employment that did not discriminate based on race. Eventually affirmative action policies started being implemented in university admissions, and there were a number of Supreme Court cases in the United States that challenged the fairness and constitutionality of race-based affirmative action. One of the highlighted cases that set precedence for all other affirmative action cases was *Baake v. Board of Regents* in which the Supreme Court essentially found that universities can use race in the admissions process but it must be used in conjunction with other factors. One of the challenges that the United States has faced when it comes to the use of affirmative action is it seems as though through various affirmative action cases that a consensus could never be drawn on the conditions in which race should or should not be used in college admissions. The Court decided that either strict scrutiny had not been applied or the right level of strict scrutiny had not been used appropriately. This continues to be a problem between the Supreme Court and the lower courts.

Affirmative action did not take effect until much later in Brazil. Before affirmative action, Brazil did not have any formal laws set in place that addressed race. Affirmative Action in Brazil has taken a slightly different route that the United States remains strongly against: quota systems. After decades of black Brazilian movements that had been pushing for equality and trying to gain the government's attention about the inequalities that afro-Brazilians and indigenous people still face on an everyday basis, affirmative action was introduced as a catalyst for change. The push from the black Brazilian movements made the Brazilian government finally assess the race situation that they had long been avoiding. Affirmative action policies in regards to higher education did not come into effect until 2003 when President Luiz Ignacio "lula" da Silva took office. Affirmative action policies were not implanted until

President Lula's presidency in 2001. One of the first initiatives that Lula created in the early wake of his presidency was form the Special Secretariat of Policy and Promotion of Racial Equality (Contesting Dev. Chp 13). This new asset to the Brazilian government was created to promote racial equality in Brazil, something that Brazil lacks much of.

A program which stemmed from the new Secretariat was ProUni. ProUni, also known as University for All, is a scholarship program created to serve those students which come from low income and impoverished areas. The program helps prepare them to become more ready and prepared to enter the highly competitive higher education arena. In conjunction with ProUni, a formalized affirmative action policy was set in place. The Rio de Janeiro State Legislative Assembly passed a quota law that required that forty percent of the applicants at public universities and colleges be Afro-Brazilian or indigenous descent. A large reason for the quota system was the disparity in numbers of Afro-Brazilian and indigenous students in higher education and the balance between public/private school students (Grammar Identity). The percentage in the amount needed to increase Afro-Brazilian and indigenous students would vary on the state due to the racial makeup of that state. The first university that implemented affirmative action policy was the University of Brasileria. Slowly other universities in Brazil started adopting these policies as well.

Another policy that universities that began to include along with quotas was giving bonus points on the competitive entrance exam in Brazil called the *vestibular* (Race-Based). This test would be the American version of college entrance exams such as the GRE. The vestibular is extremely competitive. Students coming from the private schools are usually more prepared due to the curriculum taught there and their families tend to have the financial means to pay for preparatory classes (Race-Based). The curriculum of the public schools in Brazil sometimes does not prepare the students for the vestibular effectively and many of the students cannot afford to take those extra classes to help them. The extra

points on the test would allow more of the public school students to be admitted into universities. The argument that was made against this system by many, is that giving these students extra points to get them into a university does not mean they will necessarily be able to sustain their studies once they arrive and may eventually drop out. That is a valid assumption but there is also the possibility that the student may exceed expectation and be successful in their studies. The quota system and point system gives those students who may not have the best scores, socio-economic situation, and those that remain underrepresented, at least a chance of gaining a higher education in order to improve their situations.

President Dilma Rouseff took office after Lula da Silva and she continued the former president's work with affirmative action by signing a law in 2012 called the Law of Social Quotas (Telles 2013). The law stated that universities must accept fifty percent or half of their students from public schools. Afro-Brazilian and low-income students would greatly benefit from this law because most of the students coming from the public school are Afro-Brazilian, indigenous, and low-income students who cannot afford to go the prestigious private schools. The law requires that all the federal universities needed to be actively implementing this policy at their institutions by 2016.

A large challenge that affirmative action continues to face is identifying the students that will qualify to benefit from the quotas. In Brazil there are a various amount of ways to identify oneself. Some identities are by colors of skin and some are through ancestry. Negro, pardo, preto, Afro-Brazilian, and Afro-Descendent are a few ways to identify those that would be considered black by United States standards (Long 2013). Many students either do not want to identify as a darker colored person or black person because of the stigmas that come with identifying as such. To be black in Brazil is not seen as desirable to many. Black Brazilians are much lower in terms of income and also have an issue with being targets of police brutality. There lies the problem of some students

wanting to identify themselves to be black. A problem that has also transpired since affirmative action policies is that some students that are considered white that have mixed race ancestry or African ancestry, have started to take advantage and identify as Negro or black in order to receive the benefits of quotas. Many universities have incorporated using “photographs or interviews” to help in the admissions process when determining which individuals will meet the quota qualifications (Long 2013). This aspect of affirmative action is what makes things even more complex because of the many different ways that a student can identify themselves.

## DISCUSSION AND CONCLUSION

So far this paper has examined how affirmative action works in each nation, but more importantly to understand the direction that it may take for each nation, it is necessary to explain why the world has seen affirmative action take the course that it has through the political arena. To begin, in the United States, white conservative political interest have dominated the political arena. In the case of affirmative action the conservative viewpoint is especially interesting to analyze in relation to understanding why affirmative action has not played out in the most constructive way. The main argument of why race should not be included in affirmative action, or why affirmative action should not exist at all for those against it, is if the United States as a whole is trying to get beyond racism and discrimination, why use the very thing that causes so much disconnect as the basis towards equality for all? Minorities, especially African Americans in the United States continue to suffer from the political decisions of the past. The Jim Crow era in many respects caused more detriment to African Americans than slavery did. Jim Crow was two steps back since the abolition of slavery. Jim Crow created the environment that put African Americans at a great disadvantage that has resonated from generation to generation. Jim Crow not only caused physical separation among the races but also a separation that caused African Americans to fall into a place of mental slavery. Federal

laws were set in place to ensure inequality and keep some races at the bottom of the socio-economic ladder while white Americans had free reign to do as they pleased without fear. During the Crow era, African Americans were continually told that they were inferior and also shown that they did not deserve the same opportunities as white Americans had. That is still very relevant and apparent now. It cannot be denied that despite all of those obstacles there are some African Americans who have been able to reach those high goals and be successful, but collectively as a people there is still so much inequality that exists.

A famous quote that the conservatives use to guide their campaign for equality is through Martin Luther King Jr’s I Have a Dream speech, “...to not judge them by color of their skin, but by the content of their character (I Have a Dream).” They use this quote as a mechanism to show the country that affirmative action is counteracting what King believed in and dreamed for this country. He did dream and hope for the United States to reach a place where this idea exists, but unfortunately it has not happened yet. Dr. King and many others knew that dream would not happen within a few years. It has been fifty one years since the Civil Rights Act of 1964 and fifty five years since King’s speech; the work is far from being over. Since the conservative Reagan administration, the notion was that the United States would be a color-blind society if they took out affirmative action. Then race would not matter and everyone would be equal. That is something that the United States can strive towards but many doors need to be opened in order for that to happen. The only way for any situation to turn around and become better, is to attack it full on. The United States continues to have an issue with race because most of the American people are tired of talking about race and have settled to accept that things are the way they are. More conversation, interaction, and education between and within races is what can make policies like affirmative action successful. There is too much talking at each other rather than with each other. Regardless of race, when discussing race and racism it is so much easier to tell someone that they are wrong

and continue to remain in ignorance than working together to learn to value those differences in perspectives and use those as tools of empowerment. For example in the civil rights movement, it was not just black Americans that were protesting and fighting for equality—it included white Americans as well as other minorities. It was a collective effort.

Alternatives to affirmative action connects with Ronald Walters's theory of white nationalism of how racism discretely transpires through public policy. The Bush brother's percent plans are a perfect example. Their plans centered on the idea of removing race from the equation by "playing it safe" and remaining neutral on the subject. White nationalists appear as though they are fighting for policies that fight for equality for everyone, but when a policy leans a little more towards people of color, they detract. They want to foster the idea of equality without having to bring race into the picture. The point is you cannot bring about equality without understanding the decades of oppression that a race went through and the long term consequences that remain with them. The political leaders that have the power to bring about meaningful change are too skeptical and apprehensive about seeming partial or giving preferential treatment to people of color. Affirmative action is not about "preferential treatment;" it is about justice. Justice has been served in small capacities but affirmative action, especially in higher education, is one of the keys that can build a foundation for equality in all institutions of society. The things that are taught in college are not only what lead people to success but to remain successful, and if they fail, they have learned those necessary tools to build themselves back up. Higher education is one of the most valuable opportunities. It opens up endless possibilities that many people of color would never have aspired to dream of because society has instilled in their minds that they are set up to fail before they even get the chance to try. When they achieve success and know how to manage it they can take what they have learned and take it back to their communities. The more minority students that are able to enter college and going on to establish a

successful life, it will become a chain reaction and break the generational curses of oppression.

Laws intended to foster discrimination, such as Jim Crow, have long been removed; however that does not mean that the legacy of those laws have died. It is hard to understand how a nation who has suffered from an extensive history of racial domination and discrimination would not want adopt policies that would give people of color chances at a more successful life through things such as the importance of higher education. Slavery and more importantly the era of Jim Crow has stripped away at the minds and well-being of African Americans. There are different kinds of privilege and that is something that needs to be understood when examining why affirmative action is so important. Those that are strongly against affirmative action do not always take the time to bring those small details into consideration. African Americans and minorities do not have the same level of privilege when it comes to race. This is largely due to the stigmas and stereotypes that were given from the start of slavery throughout the years and have since stuck with them.

The discrimination that effects Afro-Brazilians and others of color in Brazil is very similar to the discrimination that African-Americans and people of color experience in the United States. However there was not a formal period of discrimination like Jim Crow in the United States. Some Brazilians are starting to realize that the nation has in fact been discriminating against an entire group of people because of their ancestry and skin color more than anything through everyday racism. Through the literature it has been continuously found that Brazilians believe that they do not discriminate because they encouraged the races to mix and marry and there has never been formal separation. However Brazilians have practiced systematic racism through encouragement of racial mixing. Interracial mixing was systematically intended to remove an identity of a whole race of people in order to achieve, in their minds, a completely European, white Brazilian society. Their thought process was that if the races continued to mix for a certain amount of time, all of Brazil would be

one race and have the physical European aesthetics, which would bring the nation together as a unified body. It was even made known to the world more than a century ago at the Universal Races Congress that by 2012 that not just the black race, but the mixed race as well would become obsolete (Nascimento 2006). This was quite the opposite from the United States which at one time prohibited interracial marriage. The United States' goal was to keep the races completely separate; Brazil's goal was to unify the country through robbing an entire group of people of an identity as if they had never existed. Brazil has prided itself on being very different from the United States on the issue of race and racism. However, as a nation they do not realize that they have been guilty of the same thing. The distinction and value of skin color is something that Brazilians feel very strongly about. The lighter the skin, the more "Brazilian" one is. It has been engrained in all the races' minds that white and lighter skin is what makes you a true Brazilian. Medium skin tones, or brown, are viewed as closer to white but still not white enough. The darker skin tones are undesirable and seen as less Brazilian. More importantly not many people want to claim that they are black.

Returning back to the heavy question of what are the conditions under which affirmative action may succeed or fail in each nation, it comes down to social movement efforts, particularly these college students are being discriminated against. Social movements focus on breaking down racial micro-aggression and racist stereotypes. Students who started the I too am Harvard campaign, inspired by Langston Hughes I too am America, uses micro-aggressions that have been said about them or to them to show the impact it has on society. This relates back to using race in affirmative action because if race was taken out of affirmative action, that does not remove the micro-aggressions or preconceptions that the individuals who determine who the college accepts when they are considering the students. Educating each other on differences of culture, perspective, and history seems like a redundant solution that has not seemed to work, but the work must continue until there is a

breakthrough. The same scenario is in Brazil, but their focus is more on reclaiming and finding empowerment through the Afro, black identity. In Brazil it is not just about claiming their blackness just to benefit from affirmative action, it is much deeper than that. Black Brazilians have felt ashamed and confused as to who they are and what it means to be black in Brazil. By claiming their identity' they are being empowered and embracing.

Affirmative action does not mean schools are just letting in people of color because they are people of color. Affirmative action creates opportunity. It's not about letting in less qualified. There are many qualified people of color that have just as good of scores and academic achievements of white people but they aren't represented at the university level. It's not just about getting minorities there and saying that that has met the need for diversity. More importantly it is about bringing attention, value, and knowledge into the classroom. The professors play an important role because they are helping feed knowledge into these young minds and preparing them about what will face them when they leave school. It's about diversifying perspectives more than anything. Affirmative action is very intersectional and there are a lot of components that go along with it. Race, class, gender are intersectional factors within themselves and when you decide to take race out, you take away from an even larger picture.

## SELECTED REFERENCES

- Bailey, Stanley R., and Michelle Peria. 2010. "Racial Quotas and the Culture War in Brazilian Academia." *Sociology Compass*. 592-604.
- Blume H., Grant and Mark C. Long. 2013. "Changes in levels of affirmative action in college admissions in response to statewide ban and judicial ruling." *Educational Evaluation and Policy Analysis*.
- Bonilla-Silva, Eduardo. 2006. *Racism without Racists*. Maryland: Rowman & Littlefield Publishers, Inc.
- Carneiro, Julia. 2013. "Brazil's universities take affirmative action." *BBC*. August 28.

- <http://www.bbc.com/news/business-23862676>. (May 15, 2015).
- Cottrol, Robert J. 2013. "Jim Crow: The House the Law Built." In *Long, Lingering Shadow : Slavery, Race, and Law in the American Hemisphere*. Athens, GA, USA: University of Georgia Press. ProQuest ebrary. (May 18, 2015).
- Cottrol, Robert J. 2013. "Un Pais para Todos?" In *Long, Lingering Shadow: Slavery, Race, and Law in the American Hemisphere*. Athens, GA, USA: University of Georgia. ProQuest ebrary. (May 18, 2015).
- Feagin, Joe R. 2006. *Systemic Racism*. New York: Routledge.
- Fisher v. University of Texas. The Oyez Project at IIT Chicago-Kent College of Law. [http://www.oyez.org/cases/2010-2019/2012/2012\\_11\\_345](http://www.oyez.org/cases/2010-2019/2012/2012_11_345). (May 21, 2015).
- "Full Steam Ahead for Black Preferences at Brazilian Universities." *The Journal of Blacks in Higher Education*. 33 (Autumn):43.
- Gerber, Scott. (2014). "Affirmative Action in Higher Education." *Akkron Journal of Constiitutional Law & Policy*. 27-32.
- Gratz v. Bollinger. The Oyez Project at IIT Chicago-Kent College of Law. [http://www.oyez.org/cases/2000-2009/2002/2002\\_02\\_516](http://www.oyez.org/cases/2000-2009/2002/2002_02_516). (May 19, 2015).
- Grutter v. Bollinger. The Oyez Project at IIT Chicago-Kent College of Law. [http://www.oyez.org/cases/2000-2009/2002/2002\\_02\\_241/](http://www.oyez.org/cases/2000-2009/2002/2002_02_241/). (May 19, 2015).
- Hamilton, Charles V. 2001. ed. *Beyond racism: race and inequality in Brazil, South Africa, and the United States*. Lynne Rienner Publishers.
- "Race-Based Affirmative Action in Brazilian Public Higher Education: An Analytical Overview." *Cadernos De Pesquisa* 43. 302-327.

# Instilling Resilience in Children of Poverty

Alexis Williamson  
Bradley Witzel, Ph.D. (Mentor)

## ABSTRACT

More than sixteen million children are currently living in poverty in the United States (NCCP, 2015). If these children fail to develop resilience, then they will continue to live in the cycle of generational poverty. Generational poverty is where a family continues to live in poverty from generation to generation. In order to develop resilience, strategies must be implemented within schools in order to nurture resilience in children. This research study focused on resiliency and instilling resiliency in children living in poverty. Knowledge from administrators, teachers, and parents was gathered in order to create strategies to instill resilience in children of poverty. Administrators, teachers, and parents that participated in this study were individuals from Title I schools. Title I schools are schools where at least 50% of the school is on free/reduced lunch. In order for a student to be placed on free/reduced lunch, the family must be making a low enough income and considered to be living in poverty. Literature on resilience was used in order to support the ideas of educational personnel and parents. Concepts found in both interviews and literature was combined in order to form strategies that can be implemented inside of a classroom. Four strategies were created using concepts found in the study.

## INTRODUCTION

Child poverty is a global issue (McKinney, 2014). As of right now, almost half of the 2.2 billion children that live in the world are living in poverty. (CLASP). The United States ranks among the worst developed nations in the world with almost 22 percent of children living in poverty (NCCP, 2015). “There are nearly 24 million young children under age 6 years in the United States” (NCCP, 2015), while more than 24 million children aged 6 through 11 are currently living in poverty. Poverty is defined as lacking material needs, such as the food, fuel, healthcare, clothing, housing, and resources, due to low income (McKinney, 2014). Thus, a child living in poverty lacks some of the most essential needs to survive and thrive. Numerically, poverty is when a family household income is below 100% of the Federal Poverty Threshold (NCCP, 2015). The Federal Poverty Threshold is currently set at \$16,057 for a family of two, and it goes up to \$23,624 for a family of four (NCCP, 2015). Child poverty is linked to poor performance in both school and work for children and adults (CLASP, 2013). If a child grows up in poverty, then the odds of that child becoming successful is quite slim.

In many families, poverty is generational. Generational poverty is where families continue to live in poverty through the years or through generations. Children who are living in poverty now will continue living in poverty in the next generation. In order to stop the cycle and prevent the continuation of living in poverty, it is important that children develop resilience at a young age. Developing resilience at a young age will enable children to carry on that resilience throughout the rest of their lives. Overall, resilience is the ability to overcome adversity that one person may face in his or her life. Resiliency could be compared to sports. If an athlete is injured during the game, that athlete will have to undergo procedures and rehabilitation. Before the athlete is allowed to return back to the game, he or she must prove his or her capabilities. The athlete’s determination and perseverance to working hard in order to get back in the game is resilience. Even though the athlete was halted due to an injury, he or she pushed through the adversity in order to keep performing in the game. This current investigation will analyze how to instill academic resilience in children of poverty at the elementary level. Administrators,

teachers, and parents are people that influence a child's life. The purpose of this investigation will determine how administrators, teachers, and parents are currently instilling resilience in children so that a framework may be set to help educators and families alike. From this framework, a series of strategies will be realized that could be used by administrators, teachers, and parents in order to help instill resilience in children of poverty.

#### *Resilience*

Resilience is a topic that has been mentioned multiple times in social science literature. Resilience will be a key to help children of poverty break the cycle that they were already born in. The definition of resilience has changed over the years, and there is no consensus on an operational definition (Herrman, 2011). However, resilience has supportive research and common similarities are found between definitions. One definition of resilience, as stated by Herrman (2011), is "the positive adaptation, or the ability to maintain or regain mental health, despite experiencing adversity" (p. 258). Different types of adversities include, deficient parenting, poverty, homelessness, traumatic events, natural disasters, violence, war, and physical illness (Herrman, 2011). Poverty is defined as an adversity or as a risk factor (Masten, 2001). Risk factors are "predictors of undesirable outcomes drawn from evidence that this status or condition is statistically associated with higher probability of a 'bad' outcome in the future" (Masten, 2001, p. 228) Children who are living in poverty are facing an adversity at such a young age. However, developing resilience will be a key for children living in this situation to adapt to their circumstances. Herrman stated (2011), "Mastery of relatively minor adversity by children is important for developing resilience to later challenges." (p.259). By instilling resilience at a young age, children will be able to use the resilience later when they are faced with more obstacles. Another definition of resilience, as stated by Trevino and DeFritas (2013), is "persisting and demonstrating strong effort towards their academic goals despite barriers such as limited finances." (p. 300). Unlike Herrman's definition, Trevino and DeFritas'

definition focuses on the academic aspect of resiliency. Trevino and DeFritas define resilience as having the ability to obtain academic achievement regardless of the financial situation. Masten (2001) defines resiliency as "A class of phenomena characterized by good outcomes in spite of serious threats to adaptation or development" (p. 228). Each of these definitions focuses on a person's ability to persevere through negative circumstances. In this study, the definition of resilience by Trevino and DeFritas will be used.

#### *Intrinsic Motivation*

One's persistence and efforts are motivated by several potential sources (Witzel & Mercer, 2003). Two common categories of motivation are extrinsic and intrinsic. Intrinsic motivation occurs when someone develops internally satisfying consequences during or after the behavior, such as task completion, feedback or result, acquisition of knowledge or skills, and a sense of mastery. Extrinsic motivation takes place when someone develops satisfying consequences outside of the person such as tangible objects, token systems, and social approval. Often times when resilience is discussed, the topic of intrinsic motivation is mentioned. Intrinsic motivation is the drive that students have intrinsically to succeed. Intrinsic motivation is the passion that students have in order to be successful. In order to be resilient, one must be intrinsically motivated. It has been shown that a relationship exists between intrinsic motivation and achievement outcomes (Trevino & DeFreitas, 2013). If a child develops intrinsic motivation, then the child will experience a positive academic correlation. By seeing positive academic outcomes, children will slowly start to develop resilience. The self-determination theory is often related back to intrinsic motivation. The self-determination theory "explains the ideas of motivation including what causes motivation to manifest, what increases motivation, and what decreases motivation." (Trevino & DeFreitas, 2013, p. 294). The self-determination theory helps understand how to create intrinsic motivation and increase it within students. Intrinsic motivation requires nurturing or undermining positive potential within individuals (Ryan and



Deci, 2000). Intrinsic motivation is needed for resilience, but extrinsic motivation is not. Extrinsic motivation has been proven to negatively affect students and their development of resilience. Extrinsic motivation is the use of external rewards to encourage motivated or positive behavior. It often uses wealth, fame, popularity, and other tangible rewards (Trevino & DeFreitas, 2013). Students who depend on extrinsic motivation show less interest and less persistence in their academics. With intrinsic motivation, students showed more interest and value in what they were learning. Intrinsic motivation is critical for the development of resilience in students.

#### *Racial Identity and Racial Climate*

The racial identities of students and the racial climate of the school are both factors of developing resilience in students. Students who identify positively with their race or their race's historical background, have shown positive values and achievement (Byrd & Chavous, 2011). When students associate with the negative stigmas related back to their racial group, then the students will perform poorly. The negative stigmas will act as a barrier for the students. However, if students are shown the positive qualities of their racial group, the students will become more motivated to succeed. This leads back to intrinsic motivation. A positive racial identity leads to positive academic achievement. Racial climate also influences the development of resilience in students. A school's racial climate or even a classroom's racial climate affects student's intrinsic motivation. If a racial group is ignored or not acknowledged in a school or classroom, then students will not be motivated to succeed (Byrd & Chavous, 2011). If a racial group is acknowledged in the school or classroom, then positive academic achievement can be expected. If a racial group is shown as important in the classroom or in the school, the students of that racial group will feel more motivated to excel in their studies (Byrd & Chavous, 2011). Most students who are in poverty are of the African American and Hispanic race. In 2012, 37.5 percent of children in poverty were African American while 33 percent were Hispanic (CLASP, 2013). In order to instill resilience, it is

essential to consider racial identity and racial climate essential.

### **CURRENT STUDY**

The current study will be focusing on how to instill resilience in children of poverty. Resilience will enable children of poverty to go beyond their circumstances and possibly break the cycle of poverty. The most influential people in a child's life are their teachers, parents, and administrators. This study will gain knowledge from administrators, teachers, and parents of children who attend Title I schools in the Rock Hill area. Title I schools are schools where over 40 percent of children who are attending the school are on free and reduced lunch. Knowledge will be gained from the essential people in the children's lives to see what is already being done to help instill resilience, and what else needs to be done to help develop resilience. Responses gained from the subjects were compared to what has already been found in the literature to determine supportive strategies that could be used to instill resilience. The practical strategies that will be created at the end of this study could be used in schools and at home. By developing strategies that could be used at home and in school, these could help bridge the gap between school life and home life. Creating these strategies to develop resilience might be able to break the cycle of generational poverty. Over 2.2 billion children are living in poverty currently (CLASP, 2013), which means that these children will become adults in poverty. The children who are living in poverty are destined to continue living in poverty as adults unless resilience is instilled in children now. Resilience is a key to giving children of poverty a successful and productive life.

### **METHODS**

#### *Statement of Problem*

The statistics of the amount of children living in poverty is saddening. In the U.S alone, over 16 million children are living in poverty (CLASP, 2013). That is almost 22 percent of the children population living in the U.S. Poverty is an adversity that influences a child's outcome.

“Research shows poverty is a strong predictor of children’s success in school and adult employment and earning” (CLASP, 2013). If intervention is not implemented in these children at a young age, then these children will continue to live in poverty even as adults. In order to break the cycle of generational poverty, resilience must be instilled in order to motivate children to exceed beyond their circumstances.

#### *Research Question*

This investigation focused on how to instill resilience in children of poverty. This study took expert knowledge from the individuals who work with children of poverty on a daily basis. Administrators, teachers, and parents are the three most influential people in a child’s life. The goal was to create strategies that could be used by gaining knowledge from individuals on what they are currently doing to implement resilience, and comparing it to the literature that is already on resilience.

#### *Study Design*

This study is considered a pre-experimental design. As a pre-experimental design it investigates the conditions that have already occurred and cannot be directly used for cause-effects. As such, the purpose of this research is to define variables and determine how these variables are related (Campbell & Stanley, 1963, p. 34). This investigation is exploratory research. The focus of this research was finding the themes that were most important in developing resilience, and developing friendly strategies that could be used by administrators, teachers, and parents. This investigation was focused on creating strategies that could later be used in experimental research to determine if they are effective.

#### *Data Gathering Procedures*

For this study, intensive interviewing was used in order to gather data. Intensive interviewing “permits an in-depth exploration of a particular topic or experience and, thus, is a useful method for interpretive inquiry” (Charmaz, 2006, p. 25). Subjects were interviewed in order to gain more insight on their experiences related to resilience. Subjects in this study were specifically selected to include administrators, teachers and parents from Title I schools in the Rock Hill area. Four out of the

eight Title I schools in the Rock Hill area participated in this study. One administrator was chosen from each school. Two teachers were chosen from each school, along with two parents from each school. Four administrators, seven teachers, and five parents were able to participate in the research. Recruitment for participants started with interest emails being sent to the administrators of each school. If administrators chose to participate, then recruitment letters were sent out for administrators, teachers, and parents. Afterwards, communication was made in order to set up meeting times for interviews. Once confirmed with a date, interviews were held. Each participant was asked five primary questions, with two supplementary questions following. Each set of questions was tailored to the role of the participant, but each set of questions focused on how the participants instilled resilience. The interviews lasted approximately thirty minutes. A maximum time of an hour was given if needed for the participant. The interviews were mostly held in person, but depending on the circumstances of the participants, phone and Skype interviews were offered. There was no recording of the responses of the interviews. Participants’ responses were written down. At the end of each interview, participants were given a review of what was recorded so that no misinterpretations were included in the responses.

#### *Confidentiality*

All participants in this study were anonymous. Each subject was informed that his or her identity would be protected throughout this investigation. No names were written down on the data that was gathered from each interview. The only piece of information that had names written down on it was the informed consent agreements. Each participant had to sign an informed consent agreement showing that he or she agreed to participate in the research process. All informed consent agreements will be held in a folder inside of a locked storage cabinet. No one outside of the researcher will be able to view the informed consent agreements. All identities were protected in this research.

*Coding and Analyzing*

Once all the interviews were conducted, coding and analyzing took place. Data gathered from the interviews was coded and analyzed. This study used Grounded Theory in order to analyze and synthesize data. Grounded Theory “consists of systematic, yet flexible guidelines for collecting and analyzing qualitative data to construct theories ‘grounded’ in the data

themselves” (Charmaz, 2006, p. 2). Data gathered from the responses of the interviews was referred back to the literature to find common themes. Triangulation was also used between the responses of educational personnel, parents and the literature. Triangulation consisted of taking data from three different sources and finding correlation between all three of the resources.

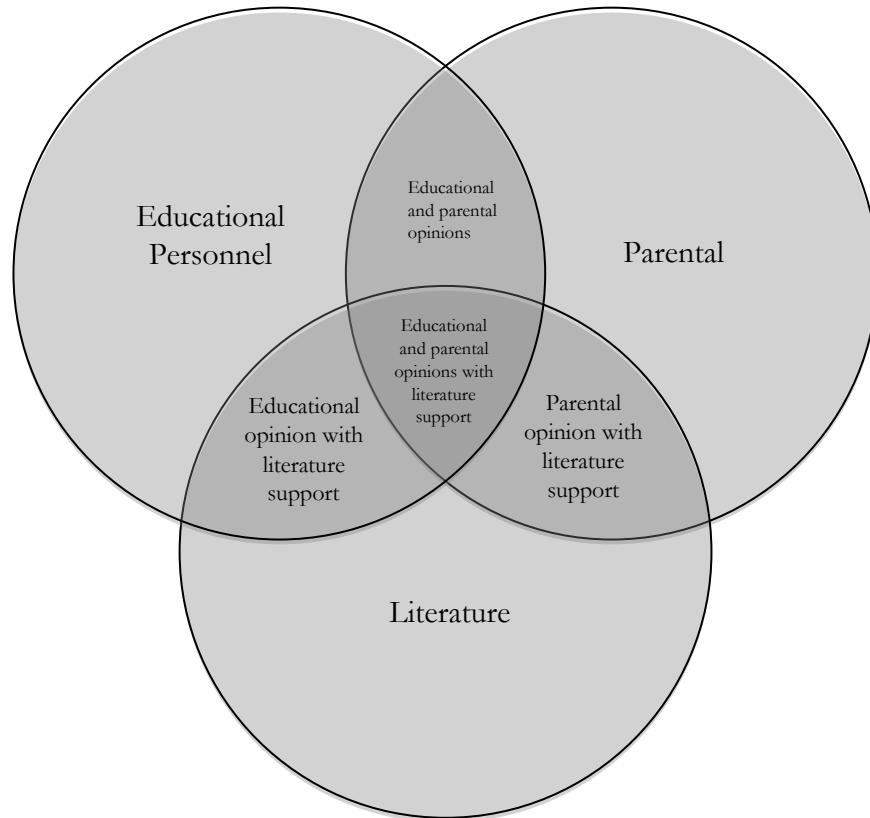

**Figure 1:** Triangulation between educational personnel, parents, and literature

The common themes were used in order to produce strategies that could be used at home and inside of the classroom.

#### *Summary*

This entire study is a pre-experimental design. The goal of this research is to develop strategies based off of the literature and the knowledge of particular individuals. In this investigation the individuals were administrators, teachers, and parents of Title I schools in the Rock Hill area. Interviews were conducted in order to collect data. The data in this study consisted of the knowledge and opinion from administrators, teachers, and parents about how they are instilling resilience in their students/children. All identities in this study remained anonymous. All identities were protected, with the paperwork that has names being locked in a storage cabinet. Data gathered was coded and analyzed with the literature. Grounded Theory and Triangulation was the main two methods used in order to code and analyze information gathered. Strategies were created based off of the themes found.

### **RESULTS**

After conducting sixteen interviews and undergoing two phases of triangulation, three main themes were found. Positivity, Relationships, and Self-Regulation were the three themes that not only appeared throughout all of the interviews, but also has foundation in the literature about resiliency. Having a positive attitude and setting high expectations for students will encourage resiliency in the students. Benard states “research has indicated that schools that establish high expectations for all youth—and give them the support necessary to achieve them—have high rates of academic success” (1995). Inserting positivity in a child’s life and setting high expectations of that positivity could instill resiliency in that child. Relationships are another key theme that is important to developing resiliency. “At a time when the traditional structures of caring have deteriorated, schools must become places where teachers and students live together, talk with each other, take delight in each other’s company...It is obvious that children will work harder and do things...for people they love and

trust” (Benard, 1995). Relationships must be built not only between students and teachers, but also between peers, child and parent, and also teacher and parent. A teacher from one of the schools that participated in the study stated “It is important to build a relationship with your students, you must earn their trust and respect.” By developing relationships with students living in poverty, teachers or parents will be able to encourage the child and also express positivity. That will slowly develop resiliency in the child without the child even realizing it. The last theme that was found within this study was Self-Regulation. Allowing children the freedom to make decisions or take control over their own path can instill resilience in a child of poverty. Self-Regulation deals with a person being able to control one’s emotions, self-control, self-esteem, etc. Allowing a child living in poverty the ability to make decisions or to actively participate will help encourage resiliency. “Participation, like caring and respect, is a fundamental human need” (Benard, 1995). Allowing active participation and giving out responsibilities will not only help with Self-Regulation, but it could also help strengthen relationships and encourage positivity. All three themes work as a continuous cycle, if one theme is implemented then the other two themes can be found. From these three themes, four strategies were created. Each of these strategies can be used inside of the classroom. Each of the strategies focuses on one or more of the themes found in this study.

- |   |
|---|
| <p><b>1. Daily individualized optimistic messages for each student (Positivity &amp; Self-Regulation).</b></p>                |
| <p><b>2. Monthly/Weekly goals for individual students and as a classroom as a whole (Positivity &amp; Relationships).</b></p> |
| <p><b>3. Community-building activities or assignments on a weekly basis (Positivity, Self-Regulation, Relationships).</b></p> |

- |  |
|--|
| <p><b>4. Let students play an active part in decision-making within the classroom and individually with themselves (Self-Regulation &amp; Relationships)</b></p> |
|--|

**Figure 2:** List of strategies based on the three themes (Self-Regulation, Relationships, and Positivity).

## CONCLUSION

The next step for this study will be to implement the strategies found in the pre-experimental portion of this study inside of an elementary classroom. Preferably one of the schools interviewed would be one of the schools to participate in the next stage of this study. A longitudinal study would most likely be used in order to gather significant enough progress and data. Implementing these strategies over an entire school year or through a semester of school would be ideal. Students who are deemed at risk will be the students that the study focuses on, but the entire classroom will experience the four strategies being implemented. A pre and post survey will be done in order to track growth and to see if the implantation of the strategies has an impact on the development of resiliency in children of poverty. The next phase of this study would be to see if these strategies are effective or if there is another focus that needs to be looked at when developing resiliency.

## REFERENCES

Byrd, C.M., & Chavous, T. (2011). Racial identity, school racial climate, and school intrinsic motivation among African American youth: The importance of person– context congruence. *Journal of Research on Adolescence*, 21 (4), 849-860.

Benard, B. (1995). Fostering resilience in children. *ERIC Digest*.

Berliner, D.C. (2006). Our impoverished view of educational research. *Teachers College Record*, 108(6), 949-995.

Campbell, D.T., & Stanley, J.C. (1963). *Experimental and quasi-experimental designs for research*. Boston, MA: Houghton Mifflin.

Charmaz, K. (2006). *Constructing grounded theory: Practical guide through qualitative analysis*. Thousand Oaks, CA: SAGE.

Center for Law and Social Policy (2013). Child poverty in the U.S: What new census data tell us about our youngest children. Retrieved from [http://www.clasp.org/admin/site/publications/files/9.18.13-CensusPovertyData\\_FactSheet.pdf](http://www.clasp.org/admin/site/publications/files/9.18.13-CensusPovertyData_FactSheet.pdf).

DeFreitas, S.C., & Trevino, N.N. (2014). The relationship between intrinsic motivation and academic achievement for first generation Latino college students. *Social Psychology of Education: An International Journal*, 17 (2), 292-306.

Herrman, H., Stewart, D. E., Diaz-Granados, N., Berger, E. L., Jackson, B., & Yuen, T. (2011). What is resilience?. *Canadian journal of psychiatry*, 56(5), 258-265.

Jiang, Y., Ekono, M., & Skinner, C. (2015). Basic facts about low-income children: Children under 6 years, 2013. *National Center for Children in Poverty*. New York, NY.

Jiang, Y., Ekono, M., & Skinner, C. (2015). Basic facts about low-income children: Children 6 through 11 years, 2013. *National Center for Children in Poverty*. New York, NY.

Masten, A.S. (2001). Ordinary magic: Resilience processes in development. *American Psychological Association*, 56(3), 227-238.

Özkan, Y. (2010). Interpersonal impact of the poverty on children. *International Journal of Academic Research*, 2(6), 172-177.

McKinney, S. (2014). The relationship of child poverty to school education. *Improving Schools*, 17(3), 203-216.

Witzel, B. S., & Mercer, C. D. (2003). Applying rewards to teach students with disabilities: implications for motivation. *Remedial and Special Education*, 24, 88-96.

## Scholars' Research Published Elsewhere

The following Scholars do not have work included here because they are preparing manuscripts for publication in peer-reviewed professional journals.

### **Emily Hokett**

Mentor: Dr. Sarah Reiland, Psychology

### **Lauren Green**

Mentor: Dr. Matthew Stern, Biology

### **Jordan Lewis**

Mentor: Dr. Matthew Heard, Biology

### **Olivia Manley**

Mentor: Dr. Nicholas Grossoehme,  
Chemistry

### **Kyle McDaniel**

Mentor: Dr. Julian Smith, Biology

### **Malyn Pope**

Mentor: Dr. Merry Sleigh, Psychology

## Thank you

### **Scholars**

Your commitment to excellence and persistence through multiple challenges during your research process are inspiring. Thank you for your responses to the many requests for editorial changes and information. The high quality of your work reflects well on you and on the program.

### **Mentors**

Thank you to each of our Mentors for sharing expertise with the Scholars and staff. Your support throughout the research and graduate admissions processes are critical to helping our Scholars' excellence shine brightly for all to see. Words are not sufficient to express the gratitude the McNair Scholars and staff feel for the investments you have made in these outstanding students.

### **Stephanie Bartlett**

Just as our Mentors supported the Scholars throughout the research process, our McNair Writing Coach has supported the Scholars and Director through the preparation and documentation the Scholars' high quality research, including this *Bulletin*. Our written products would not be as impressive without your good work and eagle eyes. Thank you, Stephanie, for your continued service in Winthrop's McNair Program.

### **Dr. Matt Hayes**

The Scholars, staff, and often Mentors, rely on the knowledge and skills of our Stats and Methods Coach, Dr. Hayes. Thank you, Dr. Hayes, for meeting with the Scholars throughout their research process, to help them design high quality research projects; walk them through the process of running, interpreting, and understanding statistical analyses; and prepare to disseminate their work to a variety of audiences.